

## Installation for Voyager Brake Control

### Electronic Brake Control For 2, 4, 6\* and 8\* brake applications [\*6 and 8 brake for XP model only]

#### READ THIS FIRST:

Read and follow all instructions carefully before wiring brake control. Keep these instructions with the brake control for future reference.

### Components of the Brake Control

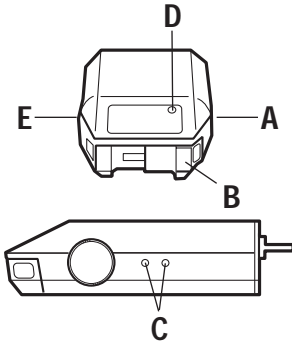

- A. Power Knob
- B. Manual Slide Knob
- C. Bracket Mounting Holes
- D. Bi-Colored Light
- E. Level Knob

### Important Facts to Remember

1. Do not mount or activate RF generating items (cell phones, two way radios) near (less than 12") the brake control.
2. Reversing the connection to a breakaway battery on the trailer will destroy the brake control.
3. Disconnect trailer plug from the tow vehicle prior to testing a breakaway switch, or you may destroy the brake control.
4. The light is:
  - GREEN when trailer is connected
  - RED when brake pedal or manual is activated and trailer is connected.
5. The GREEN light draws 10 milliamperes of current from tow vehicle. It would take over 5,000 hours to drain the tow vehicle battery.
6. The level adjustment is CRITICAL. The level adjustment determines whether automatic braking response is delayed or aggressive.
7. This brake control is activated by inertia. It senses deceleration and generates an output that reflects the inertia sensed. In a stationary state, the brake control will not apply the trailer brakes unless the Manual Slide Knob is actuated.
8. For Technical Assistance and Warranty Information call: 1-800-786-7968

### Installation Guide

**NOTE:** The Brake Control must be mounted from -20 degrees nose down to 70 degrees nose up. (See Below). Failure to install brake control within these constraints may cause your control to become inoperable.

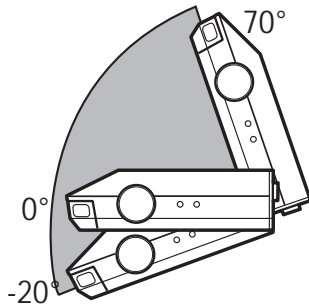

### Traditional Bracket Mount

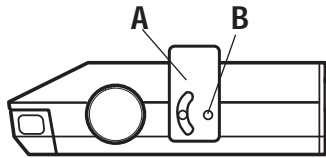

- A. Mounting Bracket
- B. #6 x 3/8" Screws

**NOTE:** Drilling or use of longer screws may damage unit.

1. Securely mount *bracket* to a solid surface.
2. Insert supplied #6 x 3/8" screws into the mounting holes.
3. Adjust control to desired position and tighten *screws* until snug.

### Leveling the Sensor

After the brake control has been securely mounted the level adjustment must be set.

#### NOTE:

1. This brake control is activated by inertia and requires the level to be set properly, or the braking response will be too harsh or ineffective.
2. To properly level the sensor, the trailer and tow vehicle must be parked on a level surface and trailer must be connected to tow vehicle.

1. Connect trailer to tow vehicle, Bi-Colored Light should glow GREEN.
2. Set power knob to maximum by fully rotating clockwise.
3. Depress tow vehicles brake pedal and hold.
4. Rotate the Level Knob counter-clockwise (towards the back of the control) until the Bi-Colored Light starts to change colors from GREEN to RED.
5. **Carefully** rotate the Level Knob clockwise (towards the front of the control) until a shade of ORANGE is visible.  
Bi-Colored Light should show:
  - DIM ORANGE for a typical setting.
  - BRIGHT ORANGE for an aggressive setting.
  - DIM RED for a more aggressive setting.

**NOTE:** Range of adjustment for the level knob from DIM ORANGE to DIM RED is 20 degrees of rotation.

6. Release brake pedal.

**NOTE:** When the brake control is leveled properly there will be very little current flowing through the brake magnets in a static state with the foot pedal depressed. The brake magnets will hum when there is current flowing through them. Anytime the Bi-Colored Light shows any color other than GREEN, there is current flowing through the brake magnets.

### Adjusting the Power to the Trailer Brakes

Once the control has been installed and properly leveled, it is necessary to set the power needed to stop the trailer during a braking event.

1. Connect trailer to tow vehicle.
2. Set Power Knob to the 12 o'clock position.
3. Drive tow vehicle and trailer on a dry level paved surface at 25 mph and apply *manual slide knob*.
  - ✓ If trailer brakes lock up:
    - Turn power down using *power knob*. (Rotate power knob toward the 8 o'clock position, counter-clockwise)
    - ✓ If braking was not sufficient:
      - Turn power up using *power knob*. (Rotate power knob toward the 5 o'clock position, clockwise)
4. Repeat Step (4) until power has been set to a point just below wheel lock up or at a sufficient force as to achieve maximum braking power.
5. Using the brake pedal, make a few low speed stops to check the Power and Level adjustments. The automatic response (brake pedal) is initiated and terminated via the stoplight switch. When the brake pedal is released, trailer braking will cease.

### Fine Tuning

Now that the Power has been set, it is time to fine tune the level setting for the majority of the stopping that you will be doing.

1. Make several slow (25 MPH) stops as if coming up to a stop sign and take notice of how the trailer brakes respond:
  - ✓ **Brakes Grab Too Much**
    - You have an Aggressive Setting: To correct this condition rotate level knob clockwise, toward you, *see below*.
    - ✓ **Trailer Tending to Push Tow Vehicle**
      - You have a Delayed Setting: To correct this condition rotate level knob counter-clockwise, away from you, *see below*.
2. Repeat until desired trailer braking is achieved.

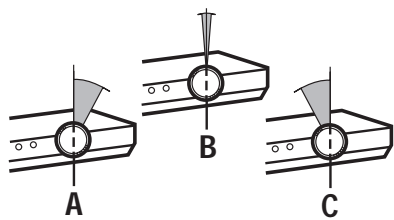

A. Delayed  
B. Normal  
C. Aggressive

**NOTE:**

1. Always warm the trailer's brakes before setting the power. Warm trailer brakes tend to be more responsive than cold brakes. To warm trailer brakes, drive a short distance (1/4 mile) at 45 MPH with manual slide engaged approximately halfway.
2. The power should never be at a level high enough to cause trailer brakes to lock up. Skidding trailer wheels can cause loss of directional stability of trailer and tow vehicle.
3. The power may need to be adjusted for different load weights and road conditions.
4. Not all trailer brakes will lock up due to various conditions.

5. When the level and power are set correctly you should feel unified braking between the trailer and tow vehicle.
6. Braking performance may be slightly sluggish in sub-freezing temperatures. Allow adequate time for the brake control to warm prior to use in sub-freezing temperatures.
7. When in doubt of the proper setting procedures review the above steps starting at LEVELING THE SENSOR through FINE TUNING or consult your tow card included with your brake control.

## Voyager Troubleshooting Chart

| Situation   | Probable Cause  |
|---|---|
| Tow vehicle connected to trailer, NO GREEN light.   | <ol style="list-style-type: none"> <li>1. Corrosion on trailer plug contact.</li> <li>2. Loose POWER or GROUND connection.</li> </ol>   |
| Tow vehicle connected to trailer, light is GREEN.<br>When Manual Slide Knob is activated: |   |
| A. No RED light.  | <ol style="list-style-type: none"> <li>1. POWER set at or near minimum.</li> <li>2. Short on BRAKE line (BLUE wire).</li> <li>3. BLACK &amp; WHITE wires reversed, control destroyed.</li> </ol>  |
| B. Light is Dim RED or flashing RED.  | <ol style="list-style-type: none"> <li>1. Open on GROUND line (WHITE wire).</li> <li>2. Short on BRAKE line (BLUE wire).</li> </ol>   |
| C. Light glows dim RED and gets brighter as POWER Knob is decreased.                      | <ol style="list-style-type: none"> <li>1. Short on BRAKE line (BLUE wire).</li> <li>2. Defective brake magnets.</li> </ol>  |
| Braking with foot pedal is too aggressive   | <ol style="list-style-type: none"> <li>1. Sensor set too aggressive, see LEVELING SENSOR.</li> <li>2. Power set too high.</li> </ol>  |
| Braking is delayed for extended period.   | <ol style="list-style-type: none"> <li>1. Sensor set improperly, see LEVELING SENSOR.</li> <li>2. Power set too low.</li> </ol>   |
| Tow vehicle connected to trailer, brake pedal depressed:                                  |   |
| A. No RED light.  | <ol style="list-style-type: none"> <li>1. Vehicle not moving, need to be moving for brakes to apply.</li> <li>2. No signal from brake light, test voltage on RED wire.</li> <li>3. Sensor set improperly, see LEVELING SENSOR.</li> </ol> |