

Template For Drilling Holes

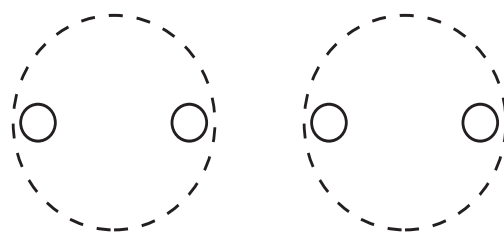

Magnetic Height Sensor

Kit No. 25415/25430

MN-601
(08506)
ECN 5233

Troubleshooting Guide

NOTE: The system has a 25 second delay before the compressor and solenoid will function.

Problem	Cause	Solution
Compressor doesn't run.	Blown fuse, bad ground, poor connection, bad compressor or ECU.	Check fuses, grounds and connections. Ground terminal 85 at relay to see if compressor runs. Unplug compressor and test.
Solenoid doesn't work.	Blown fuse, bad connections, bad solenoid or ECU.	Check fuse, connection, unplug solenoid and jumper power and ground to check operation.
Compressor runs all the time.	Leak in system, bad relay or ECU.	Locate leak, replace relay or check ECU.
Vehicle does not maintain ride height.	Bad/leaking solenoid or bad ECU.	Unplug solenoid and test by jumping power and ground.
Nothing happens when the vehicle is started.	Blown fuse, poor ground or connection.	Check fuses, connections and grounds.
	Bad ECU.	Test individual components to verify and ground terminal 85 to test compressor and harness.
	Magnet may not be properly aligned, may be backward or may be improper distance from ECU.	Check magnet alignment, distance, and insure orange dot is facing ECU.



Thank you for purchasing Air Lift Products

Mailing Address:
AIR LIFT COMPANY
P.O. Box 80167
Lansing, MI 48908-0167

Street Address:
AIR LIFT COMPANY
2727 Snow Rd.
Lansing, MI 48917

Local Phone: (517) 322-2144
Fax: (517) 322-0240

For Technical Assistance call 1-800-248-0892

"The Choice of the Professional Installer"

SMARTAIR
AUTOMATIC LEVELING ON-BOARD COMPRESSOR SYSTEM

Please read these instructions completely before proceeding with installation

Failure to read these instructions can result in mis-installation

Installing the SmartAir System

Installing the Compressor and Manifold	1
Attaching the Height Sensor Bracket	2
Attaching the Magnet and Mounting Bracket	2
*Kit Installation Diagram	3
Installing the Electrical Components	5

Troubleshooting Guide

Adjusting the System	10
Checking the System	6
Troubleshooting Diagram	6
Troubleshooting Guide	7

Important System Information

This automatic leveling system uses a position sensor along with an EHS to maintain a preset vehicle ride height.

The system is comprised of an electronic height sensor/EHS, a bracket mounted magnet, solenoid valve, relay, air compressor, and an interconnecting wire harness. This system is combined with the previously installed air bags.

The height sensor/EHS is mounted to the vehicle frame and the magnet is mounted to the axle or leaf spring. When load is added to the vehicle, the magnet rises above the EHS centerline (as the suspension is compressed). If the magnet maintains this position for a minimum of 25 seconds, the EHS will turn on the compressor, via the relay adding air to the air bags. Air is added until the magnet is re-centered restoring the vehicle to its preset ride height.

When load is removed from the vehicle, the magnet falls below the EHS and energizes the solenoid valve. This allows the air to escape from the air bags until the magnet is re-centered and the reduction in load is accommodated.

An optional kneeling system can be purchased which includes a dash mounted rocker switch. This system works to manually exhaust air from the bags when a lower vehicle is needed while parked.

Installing the Compressor and Solenoid

1. Attach the filter to the fitting on the end of the compressor.
2. Select a rigid mounting location on your vehicle's frame or crossmember that shields the compressor from the elements and heat sources (Figure 1).
NOTE: Refer to chart below for step-by-step instructions.
3. Cut a length of air line and attach one end of the air line to the compressor fitting. Attach the other end of the air line to one of the push-to-connect fittings on the tee of the pressure relief valve assembly (Figure 1).
4. Cut another length of air line and attach one end to the open push-to-connect fitting on the tee of the assembly and the other end of the air line to the solenoid valve.
5. Attach the compressor and solenoid to the frame rail or crossmember using Figure 1 as a guide.
6. Mount the solenoid as close to the compressor or air spring as possible (Figure 1). Use the template on the back of the manual for mounting the solenoid.

NOTE: It may be necessary to stabilize the pressure relief valve assembly. If so, use a tie strap and attach it to the frame rail or a crossmember.

NOTE: The compressor and manifold must be mounted within reach of the wires when the wiring harness is plugged in.

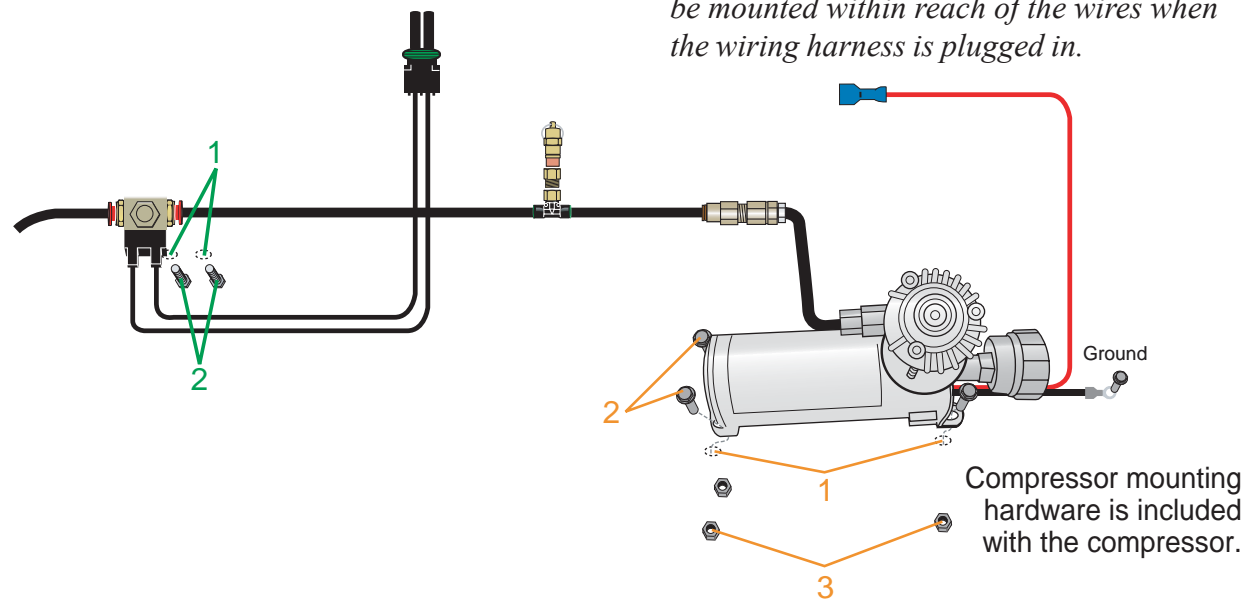

Figure 1

	1	2	3
<i>Compressor</i>	Centerpunch and drill four 1/4" diameter holes using the compressor feet as a template.	Attach using four supplied screws.	Fasten using four supplied nuts.
<i>Solenoid</i>	Centerpunch and drill two 3/16" diameter holes using the template on the back of the manual.	Attach using two supplied lock washers and bolts.	
CAUTION	Mount the compressor and manifold at least 6" from any heat sources. DO NOT mount the compressor or the manifold in the engine compartment.		

Adjusting the System

1. Make sure that the distance between the face of the magnet and the height sensor is between 3/4" and 1".
2. The bolt in the center of the magnet must be in line with the dotted line on the height sensor when the vehicle is at ride height.

CAUTION: This magnet is very strong. It is possible for the magnet to pinch skin and small body parts between another magnet or metal object.

Care should be taken when handling the magnet.

Checking the System

1. Inspect all air line connections with a solution of 1/5 dish soap to 4/5 water. Should a leak be detected in a push-lock-fitting, reinstall the air line to the fitting. Make sure air line is cut off squarely and that the air line is completely pushed into the fitting.
2. If the compressor or the solenoid fails to function, check the 20 AMP fuse and ground connection. Repair and replace as necessary.

Troubleshooting Diagram

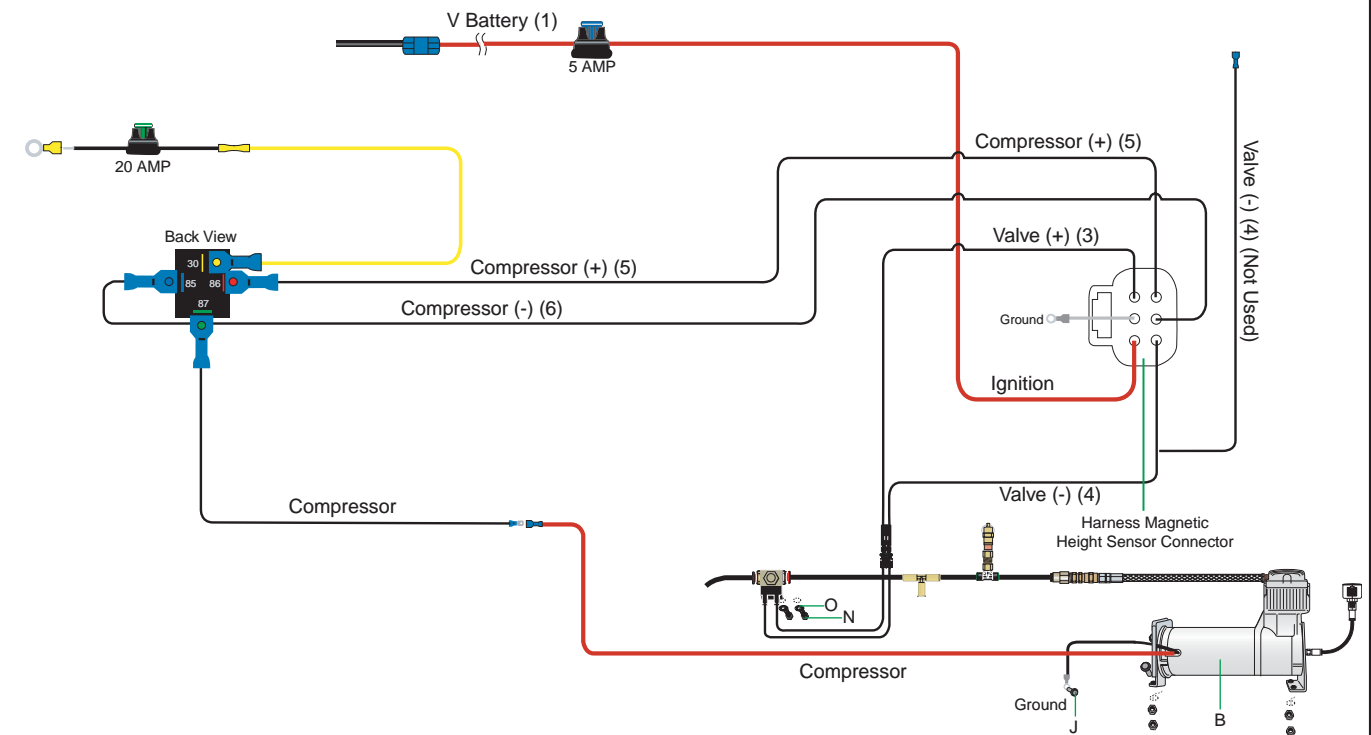

Installing the Electrical Components

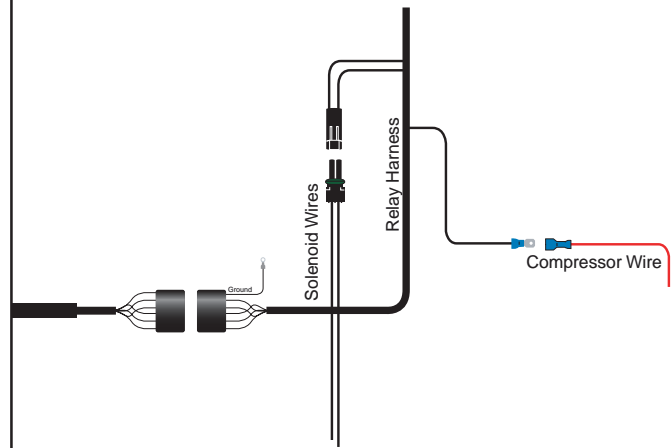

Figure 6

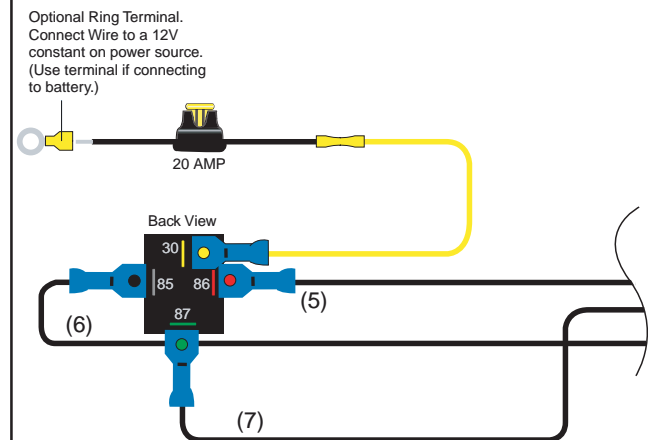

Figure 7

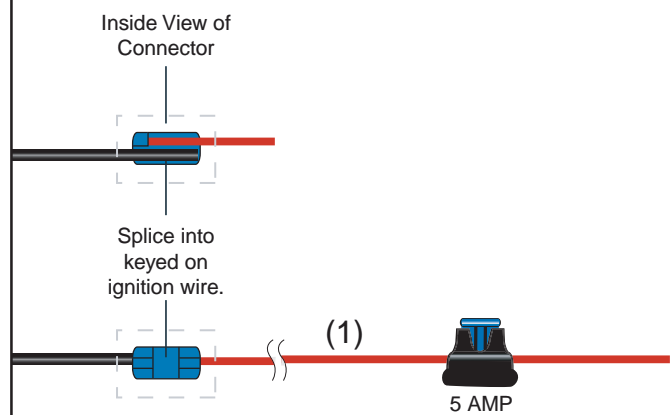

Figure 8

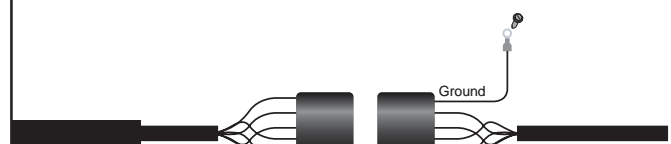

Figure 9

1. Run the harness from the cab to the solenoid/compressor location.

NOTE: It may be necessary to drill a hole so that the harness can easily pass through from the cab to the vehicle frame. Place a grommet or silicone sealant around any holes that the harness passes through to protect it from abrasive surfaces.

2. Connect single terminal connectors to connect the black compressor wire to the relay wire (Figure 6).

3. Connect the double terminal connector from the solenoid to the double terminal connector relay wires (Figure 6).

4. Splice the red wire with the 5 AMP fuse that is connected to the back of the relay to a keyed on ignition wire (Figure 8).

5. Using a butt connector, attach the 12 gauge wire from the terminal 30 on the back of the relay to one end of the 20 amp fuse holder (Figure 7).

6. If choosing to use the ring terminal, attach it to the other end of the fuse wire (Figure 7).

7. Choose an appropriate 12+ volt source on the vehicle.

NOTE: A direct connection to the battery is suggested.

8. Attach the terminal end of the ground wire to a clean section of the framerail using the provided self-tapping screw. (Figure 9).

Attaching the Height Sensor Bracket

1. Choose a mounting location along the framerail for the height sensor.
2. Using the provided screws and nyloc nuts, attach the height sensor bracket to the chosen frame-mounting location (Figure 2).

NOTE: The height sensor and the face of the magnet must be between 3/4" and 1" away from each other.

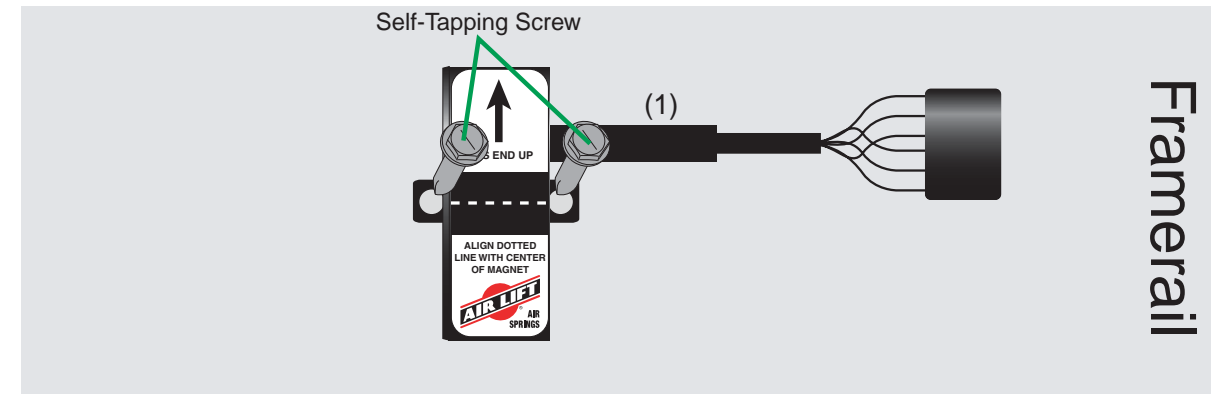

Figure 2

Attaching the Magnet and Mounting Bracket

CAUTION: The magnet has a strong pull. Use care when handling as not to pinch fingers or skin.

1. Place the supplied u-bolt around the leaf springs near the previously mounted height sensor (Figures 3 and 4).
2. Using the figures below as a guide, choose the best mounting method for your vehicle.
3. Attach the bracket to the u-bolt using the chosen mounting method using Figure 3 or 4.
4. Loosely attach the magnet to the bracket using the supplied bolt and nyloc nut.

NOTE: When choosing the mounting method, keep in mind that the center of the magnet must align with the height sensor when the vehicle is at ride height.

The magnet and the height sensor must be between 3/4" and 1" apart.

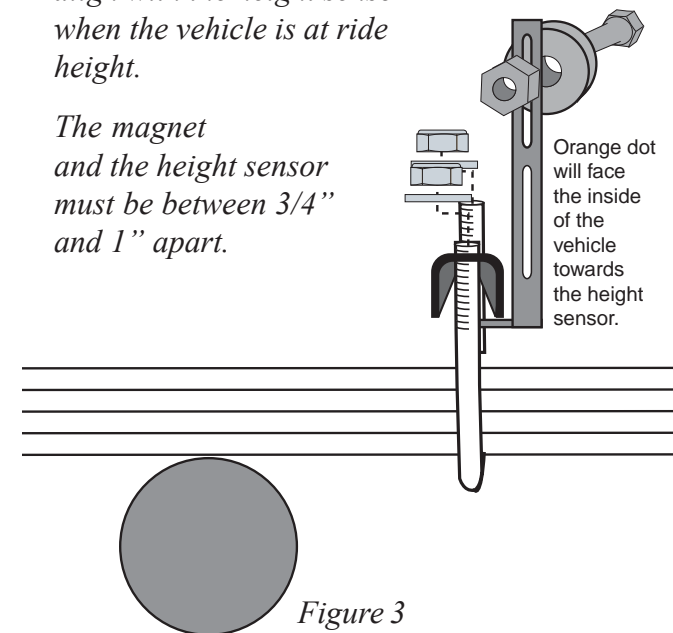

Figure 3

NOTE: There is a small orange dot on the magnet that will face the inside of the vehicle towards the height sensor.

5. Align the center of the magnet with the dotted line on the height sensor. Once the magnet is in line, securely tighten the hardware.

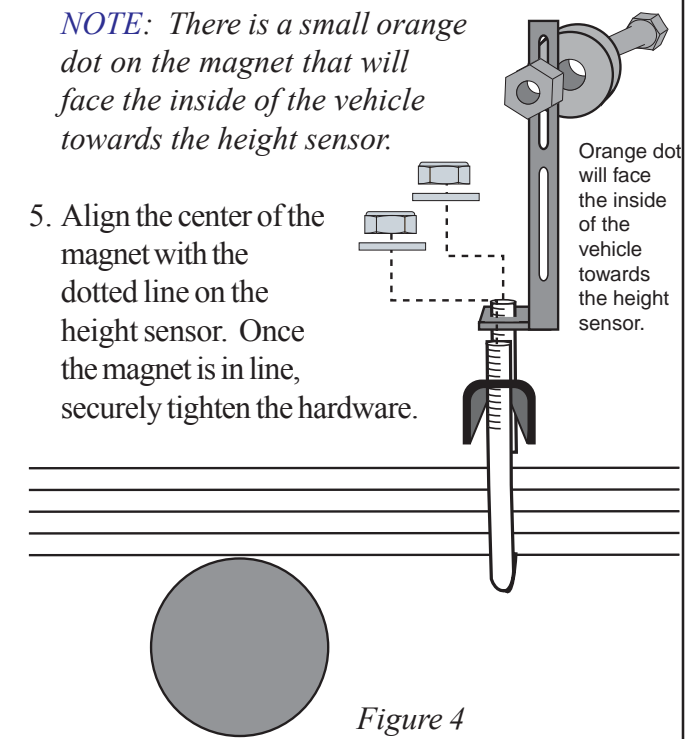

Figure 4

Kit Diagram

Kit Diagram

Hardware List

Item	Part No.	Description	Quantity
A	24050	Magnetic Height Sensor	1
B	26318	Compressor	1
C	26238	Solenoid	1
D	26687	Harness	1
E	20220	1/4" Air Line	20'
F	10966	Magnet	1
G	10967	Magnet Mounting Bracket	1
H	10466	8" Black Zip Tie	12
I	21838	1/4" x 1/4" x 1/4" Union Tee	4
J	17173	1/4" x 3/4" Self-Tapping Screw	3
N	17185	#8 - 32 x 3/8" Washer-Head Screw	2
O	18417	#8 Lock Washer	2
P	17232	#10 - 24 x 1" Hex Machine Screw	1
Q	18498	3/16 - 24 Nyloc Nut	1
R	10583	3/8" x 3.5" x 4.5" U-Bolt	1
S	01426	Clamp Bar	1
T	18435	3/8" - 16 Nyloc Nut	2
U	18444	3/8" Flat Washer	2
V	17132	#8 - 18 x 1/2" Self-Tapping Screw	1
W	26818	Pressure Relief Valve Assembly	1

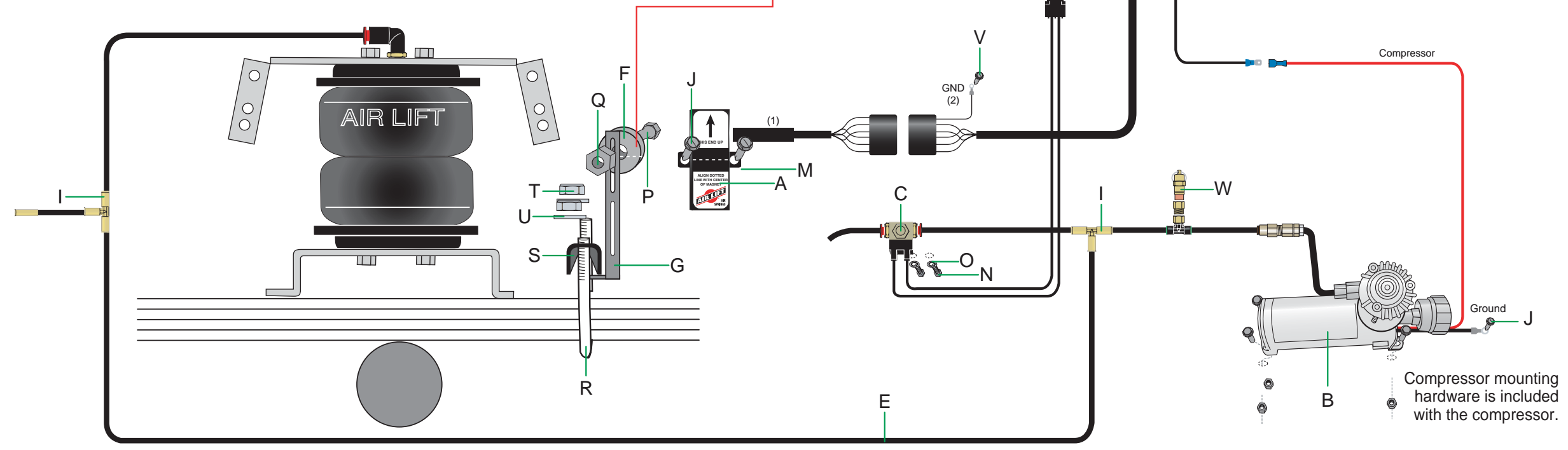
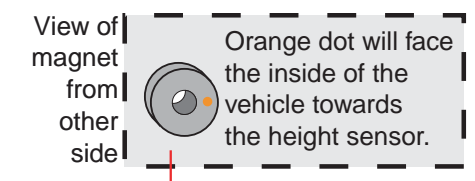
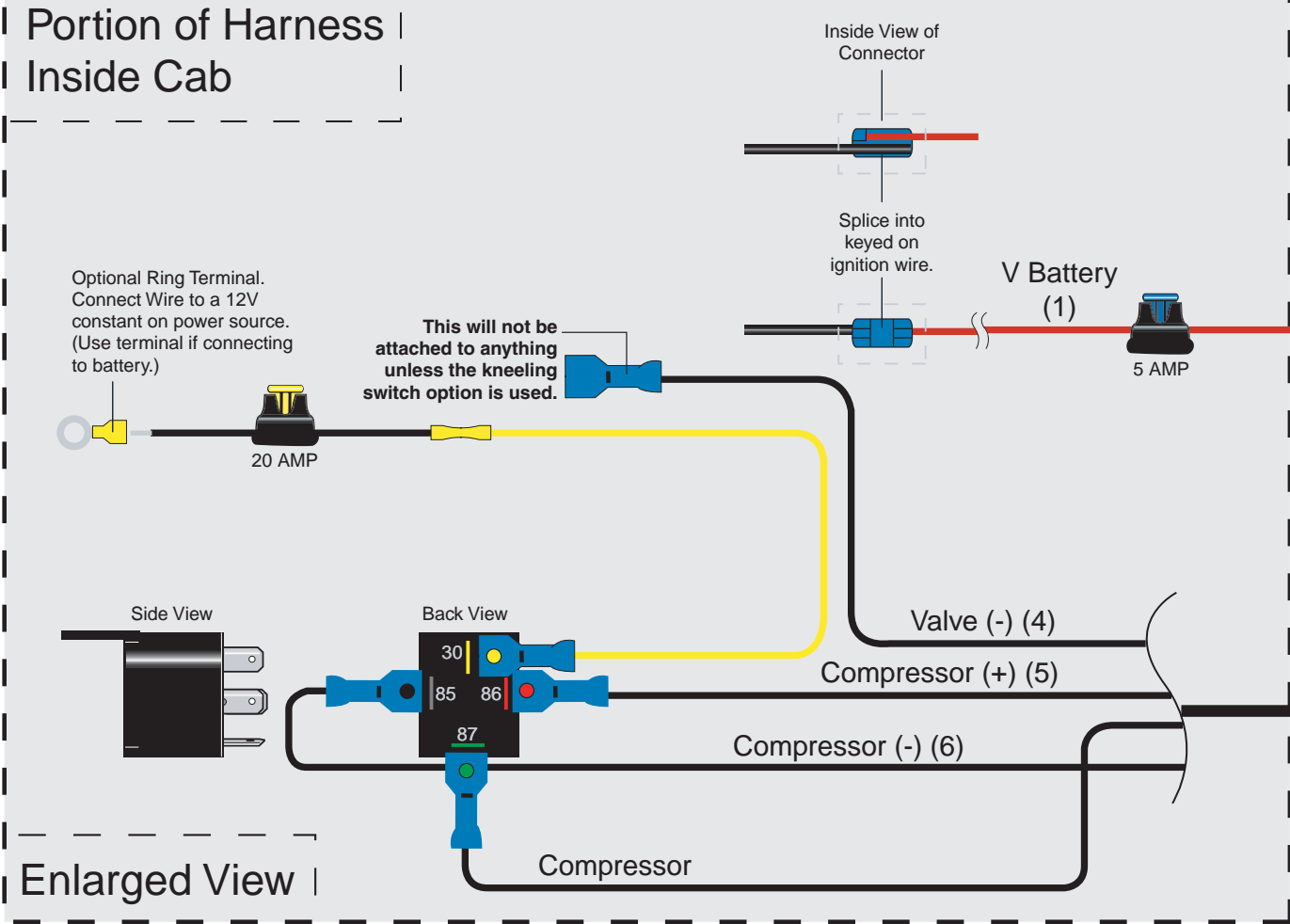

Figure 5

Installing the SmartAir System

Installing the SmartAir System