

Please read these instructions completely before proceeding with installation

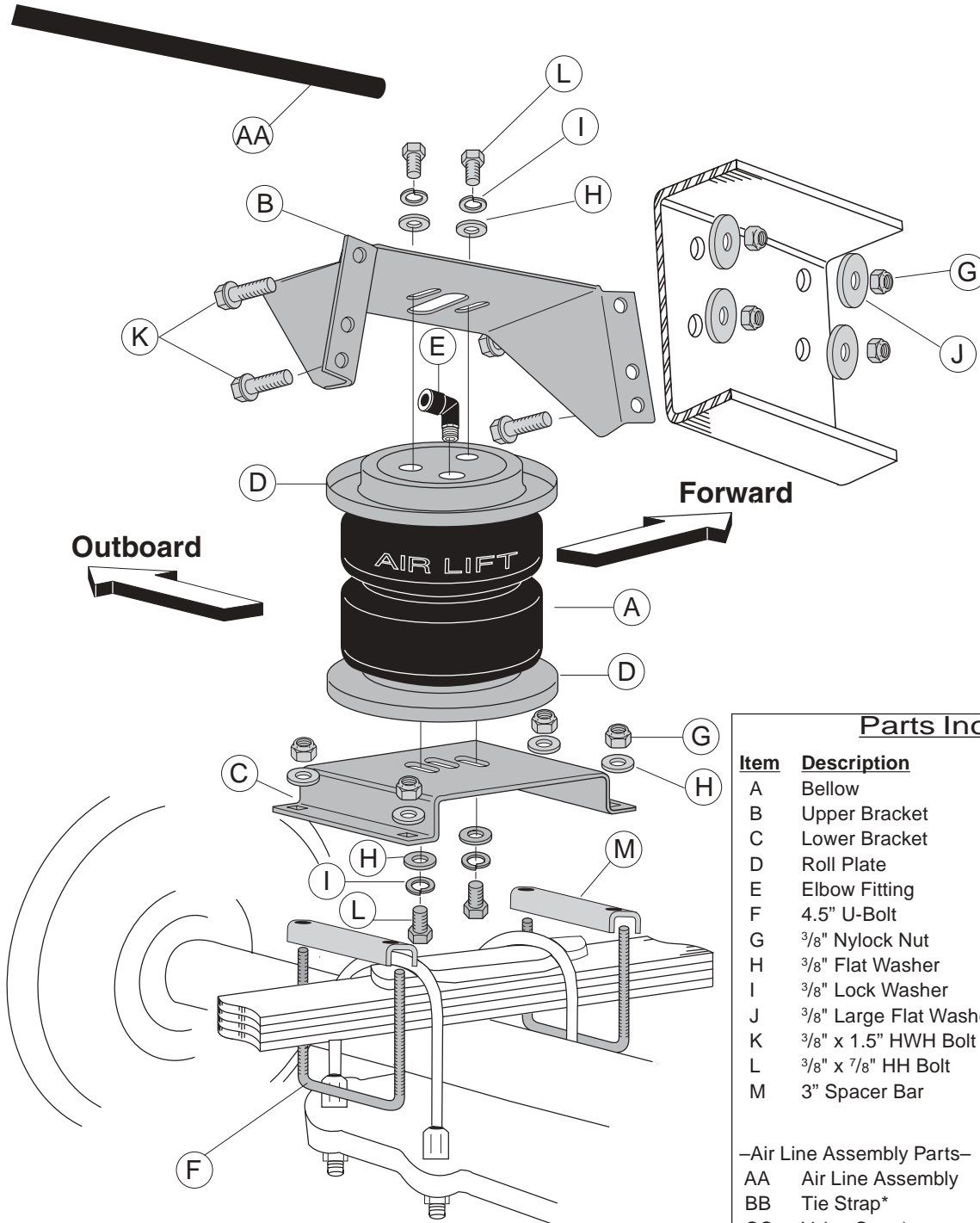

### Parts Included

Item	Description	P/N	Qty.
A	Bellow	58437	2
B	Upper Bracket	07475	2
C	Lower Bracket	03707	2
D	Roll Plate	11895	4
E	Elbow Fitting	21837	2
F	4.5" U-Bolt	10583	4
G	3/8" Nylock Nut	18435	16
H	3/8" Flat Washer	18444	16
I	3/8" Lock Washer	18427	8
J	3/8" Large Flat Washer	18447	8
K	3/8" x 1.5" HWH Bolt	17159	8
L	3/8" x 7/8" HH Bolt	17203	8
M	3" Spacer Bar	01426	4

### -Air Line Assembly Parts-

AA	Air Line Assembly	20086	1
BB	Tie Strap*	10466	6
CC	Valve Caps*	21230	2
DD	5/16" Flat Washer*	18405	2
EE	Rubber Washer*	21234	2
FF	Small Star Washer*	18411	2
GG	5/16" Hex Nut*	21233	4

(\*not shown in Figure 1)

**DANGER:** Compressed air can cause injury and damage to the vehicle and parts if it is not handled properly. For your safety, do not try to inflate the air springs until they have been properly secured to the vehicle.

## I. Getting Started

1. Raise the vehicle, remove the wheels, and support the axle with jackstands. Obtain the normal ride height.
2. Remove the jounce bumper and bracket from the side of the frame above the leaf spring (Figure 1).

## II. Assembling the Air Spring

1. Set a roll plate (D) on both ends of the air spring (A). The radiused (rounded) edge of the roll plate will be towards the air spring so that the air spring is seated in both roll plates (Cover Illustration).
2. **Install a 90° swivel air fitting (E) finger tight plus 1½" turns (Cover Illustration).** Do not overtighten.
3. Place the upper bracket (B) onto the top of the bellows and roll plate with the legs facing down.
4. Set the air spring on the lower bracket (C) aligning the two holes in the base of the air spring with the two outer slots in the top of the lower bracket (Cover Illustration).
5. Loosely attach the upper bracket to the assembly using flat washers (H), lock washers (I), and hex head bolts (L). Remember that the legs face down (Cover Illustration).
6. Loosely attach the lower bracket to the assembly using flat washers (H), lock washers (I), and hex head bolts (L). See Cover Illustration.

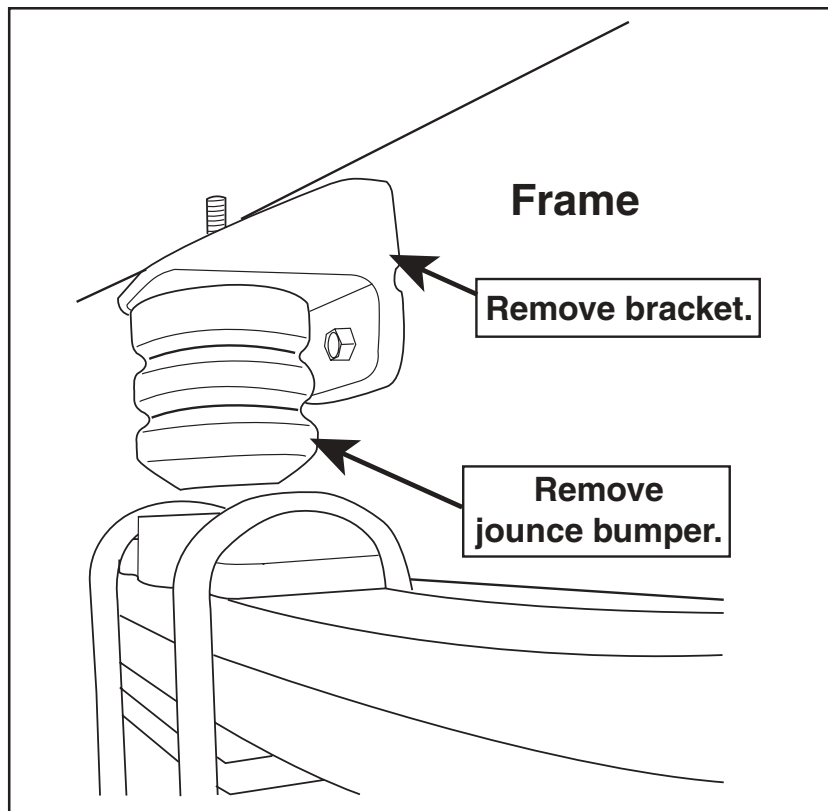

Figure 1

### III. Attaching the Lower Bracket

1. Set the assembly over the center spring retainer. Install two spacers (M) between the lower bracket and the spring (Cover Illustration).
2. Bolt the lower bracket (C) to the spring using two U-bolts (F), four flat washers (H) and four nyloc nuts (G) (Figure 4). Torque to 16 ft.lbs.
3. Trim the inside U-bolt if necessary to keep the bolt from hitting the upper bracket (Figure 2).

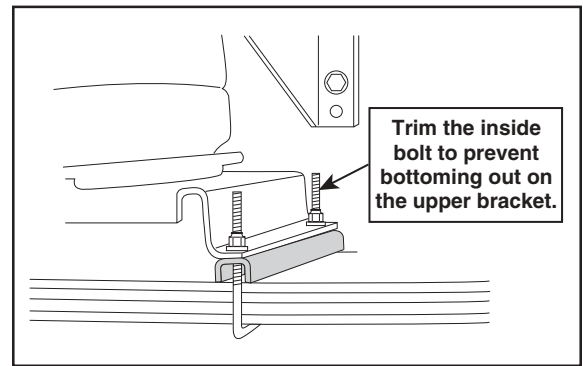

Figure 2

### IV. Attaching the Upper Bracket

**CAUTION:** Before drilling, check the back-side of the frame for clearance issues with the brake lines, gas lines, and electrical lines. Any obstacles will need to be temporarily relocated to clear the area.

1. Position the upper bracket (B) so that it is parallel with the lower bracket and align the assembly vertically and horizontally.

**NOTE:** Mount the upper bracket as high on the frame as possible. There should be a minimum of 6 inches between the upper and lower brackets (Figure 3). The top two holes may be above or even with the frame. If this is the case, use the two lower holes in the upper bracket for mounting.

2. Using the upper bracket as a template, center punch and drill one  $\frac{3}{8}$ " locator hole through the frame (Cover Illustration).
3. Attach a hex washer head frame bolt (K), oversize washer (J) and nyloc nut (G). Do not overtighten. Adjust both sides, X and Y, so that they are the same (Figure 4).
4. Drill the remaining holes. Install the appropriate hardware and torque the nuts to 44 ft.lbs.

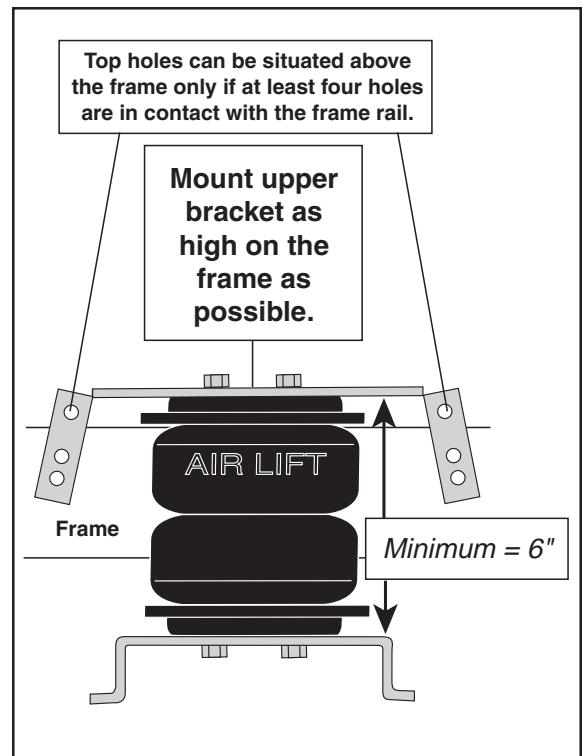

Figure 3

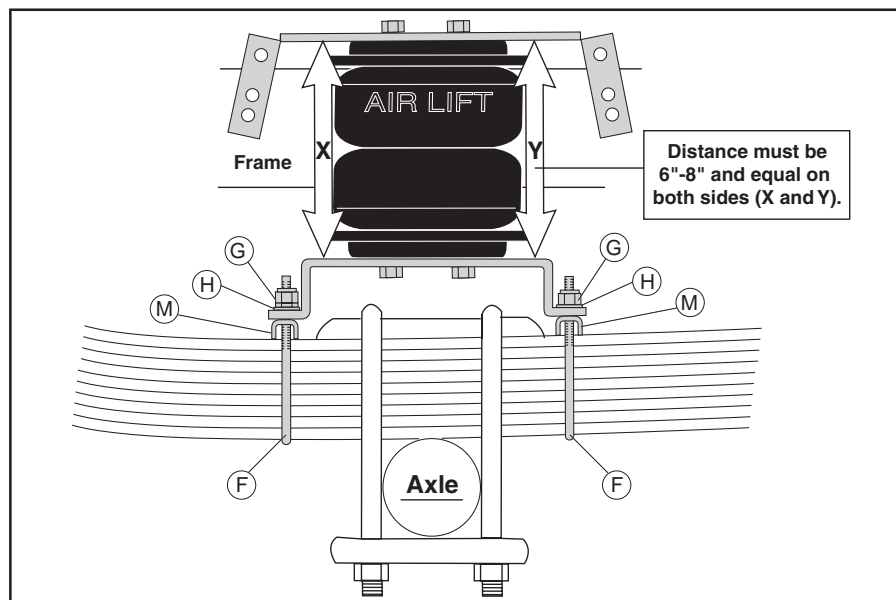

Figure 4

## V. Securing the Air Spring to the Brackets

1. Align the bellows (A) in and out so that they are perpendicular to the upper and lower brackets (Figure 5).

*NOTE: Keep a finger's width between the roll plate (D) and frame (Figure 5).*

2. Tighten both upper and lower bellows mounting bolts. Torque to a maximum of 20 ft.lbs.

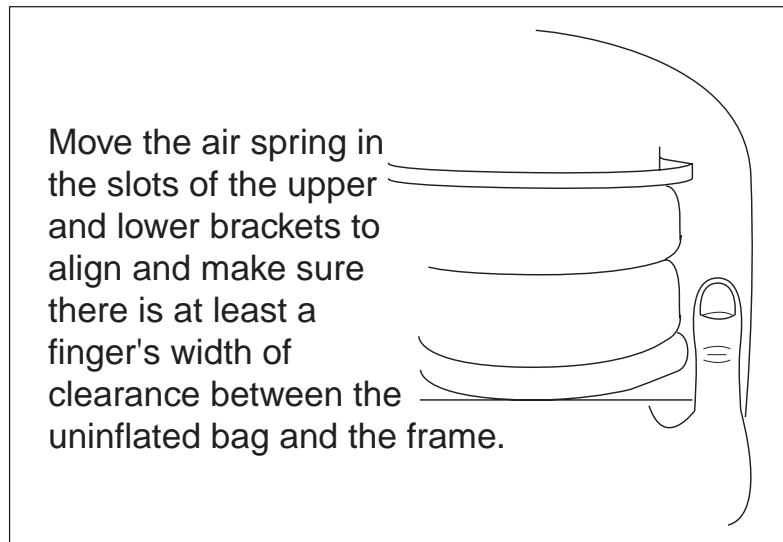

Figure 5

## VI. Relocating the Jounce Bumper

1. The jounce bumper must be relocated under the frame above the axle. First, remove the jounce bumper from the stock bracket.

2. Drill a 3/8" hole above the axle, in the bottom of the frame flange (Figure 6).

3. Mount the jounce bumper under the frame using O.E.M. hardware. Tighten securely (Figure 7).

*NOTE: Drop the axle slightly if necessary to position the jounce bumper between the frame and axle (Figure 7).*

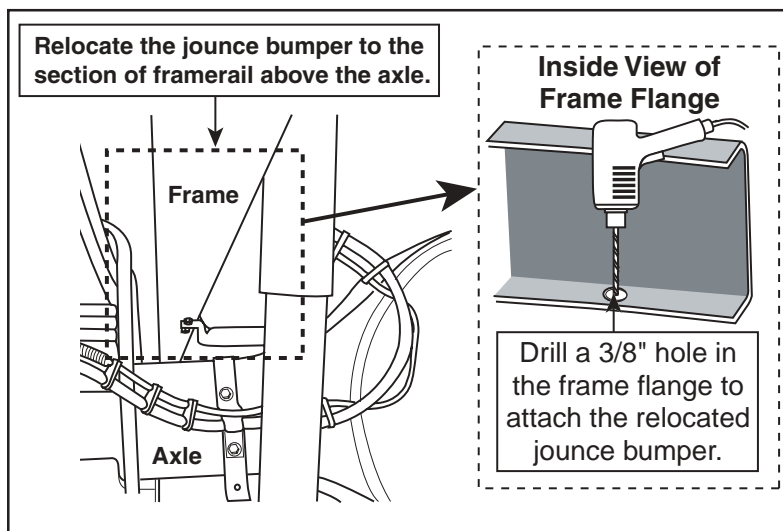

Figure 6

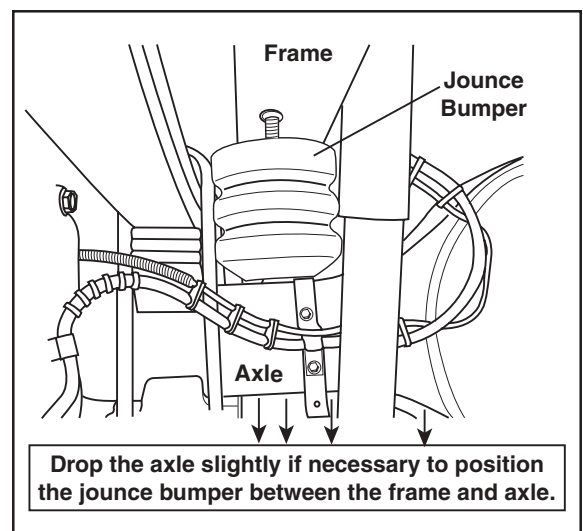

Figure 7

## VII. Installing the Air Lines

**IMPORTANT NOTE:** When installing the air lines, there must be at least six inches of clearance between the air lines and any heat sources.

1. Choose a convenient location for mounting the inflation valves. Popular locations for the inflation valve are:

The wheel well flanges; The license plate recess in bumper; Under the gas cap access door; Through license plate (Figure 10).

**NOTE:** Whatever the chosen location is, make sure there is enough clearance around the inflation valves for an air chuck.

2. Drill a  $\frac{5}{16}$ " hole to install the inflation valves.
3. Cut the air line assembly (AA) in two equal lengths.

**CAUTION:** When cutting or trimming the air line, use a hose cutter (Air Lift P/N 10530), a razor blade or a sharp knife. A clean, square cut will ensure against leaks. Do not use wire cutters or scissors to cut the air line. These tools may flatten or crimp the air line causing it to leak around the O-ring seal inside the elbow fitting (Figure 8).

4. Install the inflation valves as shown in Figure 9.
5. Keep at least 6" of clearance between the air line and heat sources, such as the exhaust pipes, muffler, or catalytic converter. Avoid sharp bends and edges. Leave at least 2" of slack when securing the air lines to allow for any movement that might pull on the air line (Figure 10).
6. Cut off air line leaving approximately 12" of extra air line. Insert the air line into the air fitting. Simply push the air line into the 90° swivel fitting until it bottoms out ( $\frac{9}{16}$ " of air line should be in the fitting).

## VIII. Checking for Leaks

1. Inflate the air spring to 30 p.s.i.
2. Spray all connections and the inflation valves with a solution of  $\frac{1}{5}$  liquid dish soap and  $\frac{4}{5}$  water to check for leaks. You should be able to spot leaks easily by looking for bubbles in the soapy water.
3. After the test, deflate the springs to the minimum pressure required to restore the Normal Ride Height, but not less than 10 p.s.i.
4. **IMPORTANT:** Check the air pressure again after 24 hours. A 2 to 4 p.s.i. loss after initial installation is normal. Retest for leaks if the loss is more than 5 lbs.

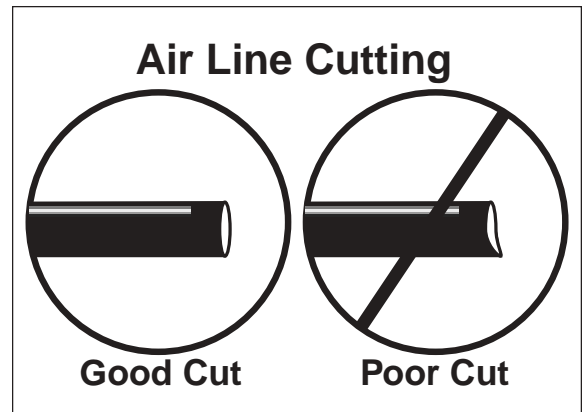

Figure 8

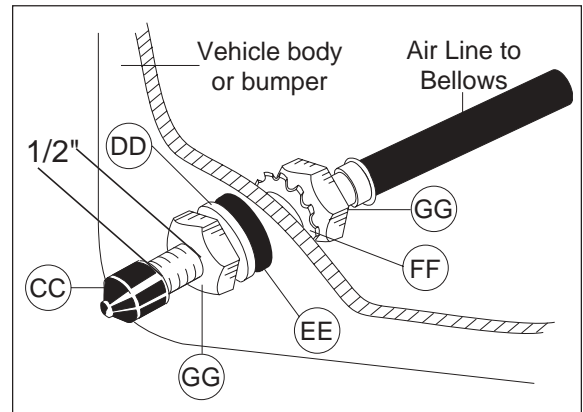

Figure 9

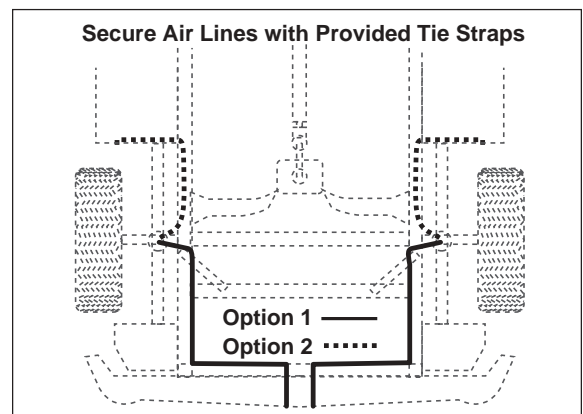

Figure 10

## IX. Maintenance and Operations

Minimum Air Pressure	Maximum Air Pressure
20 p.s.i.	100 p.s.i.
<i>Failure to maintain correct minimum pressure (or pressure proportional to load), bottoming out, over-extension, or rubbing against another component will void the</i>	

*warranty.*

*By following these steps, vehicle owners will obtain the longest life and best results from their air springs.*

1. Check the air pressure weekly and always maintain at least 10 p.s.i. air pressure.
2. If you develop an air leak in the system, use a solution of  $\frac{1}{5}$  dish soap to  $\frac{4}{5}$  water to check all air line connections and the inflation valve core before removing sleeve.
3. Inflate your air springs to 60 p.s.i. before adding the payload. After vehicle is loaded, adjust your air pressure to level the vehicle and for ride comfort. When increasing load, always adjust the air pressure to maintain the Normal Ride Height. Increase or decrease pressure from the system as necessary to attain Normal Ride Height for optimal ride and handling. Remember that loads carried behind the axle (including tongue loads) require more leveling force (pressure) than those carried directly over the axle.
4. When carrying a payload it will be helpful to increase the tire inflation pressure in proportion to any overload condition. We recommend a 2 p.s.i. increase above normal (not to exceed tire manufacturer maximum) for each 100 lbs. total overload on the axle.
5. **IMPORTANT:** For your safety and to prevent possible damage to your vehicle, *do not exceed maximum Gross Vehicle Weight Rating (GVWR), as indicated by the vehicle manufacturer.* Although your air springs are rated at a maximum inflation pressure of 100 p.s.i. The air pressure actually needed is dependant on your load and GVWR, which may be less than 100 p.s.i. Check your vehicle owners manual and do not exceed the maximum load listed for your vehicle.
6. Always add air to springs in small quantities, checking the pressure frequently. Sleeves require less air volume than a tire and inflate quickly.
7. *Should it become necessary to raise the vehicle by the frame, make sure the system is at minimum pressure (10 p.s.i.) to reduce the tension on the suspension/brake components.* Check to see that the sleeve rolls back down over the bottom piston after the vehicle is lowered (Figure 8). If sleeve fails to roll back down over the piston, add air pressure until sleeve “pops” back over piston (do not exceed 100 p.s.i.).



**Thank you for purchasing Air Lift Products**

Mailing Address:  
AIR LIFT COMPANY  
P.O. Box 80167  
Lansing, MI 48908-0167

Street Address:  
AIR LIFT COMPANY  
2727 Snow Rd.  
Lansing, MI 48917

Local Phone: (517) 322-2144  
Fax: (517) 322-0240

For Technical Assistance call 1-800-248-0892

***“The Choice of the Professional Installer”***

Printed in the USA