

Please read these instructions completely before proceeding with installation

**IMPORTANT:** This 57203 kit is for Chevy Class "A" chassis prior to 1993 and for 1993-98 Chevy Class "A" chassis with a GVWR of 14,500 pounds or less. Check your vehicle specifications. Do not use on a 1993-98 chassis with a higher GVWR. If your vehicle is 1993 or newer and has a GVWR of over 14,500 pounds, use kit 57219.

### Kit Parts List

Item	Description	Quantity
A	Air Springs	2
B	Upper Bracket	2
C	Lower Bracket	2
D	Backer Plate	4
E	Elbow Fitting	2
F	3/8"-24 x 7/8" Bolt	8
G	3/8" Lock Washer	8
H	3/8" Flat Washer	20
I	3/8" Nylock Nut	12
J	3/8"-16 x 3.5" Carriage Bolt	4
K	3/8"-16 x 1.5" Carriage Bolt	8
L	J-Strap	4
M	Thermal Sleeve	2
N	Heat Shield*	2
O	Heat Shield Clamp*	4
AA	Air Line Assembly	1
BB	Tie Strap*	6
CC	Valve Cap*	2
DD	5/16" Flat Washer*	2
EE	Rubber Washer*	2
FF	5/16" Star Washer*	2
GG	5/16" Hex Nut*	4

\* (not shown in Figure 1)

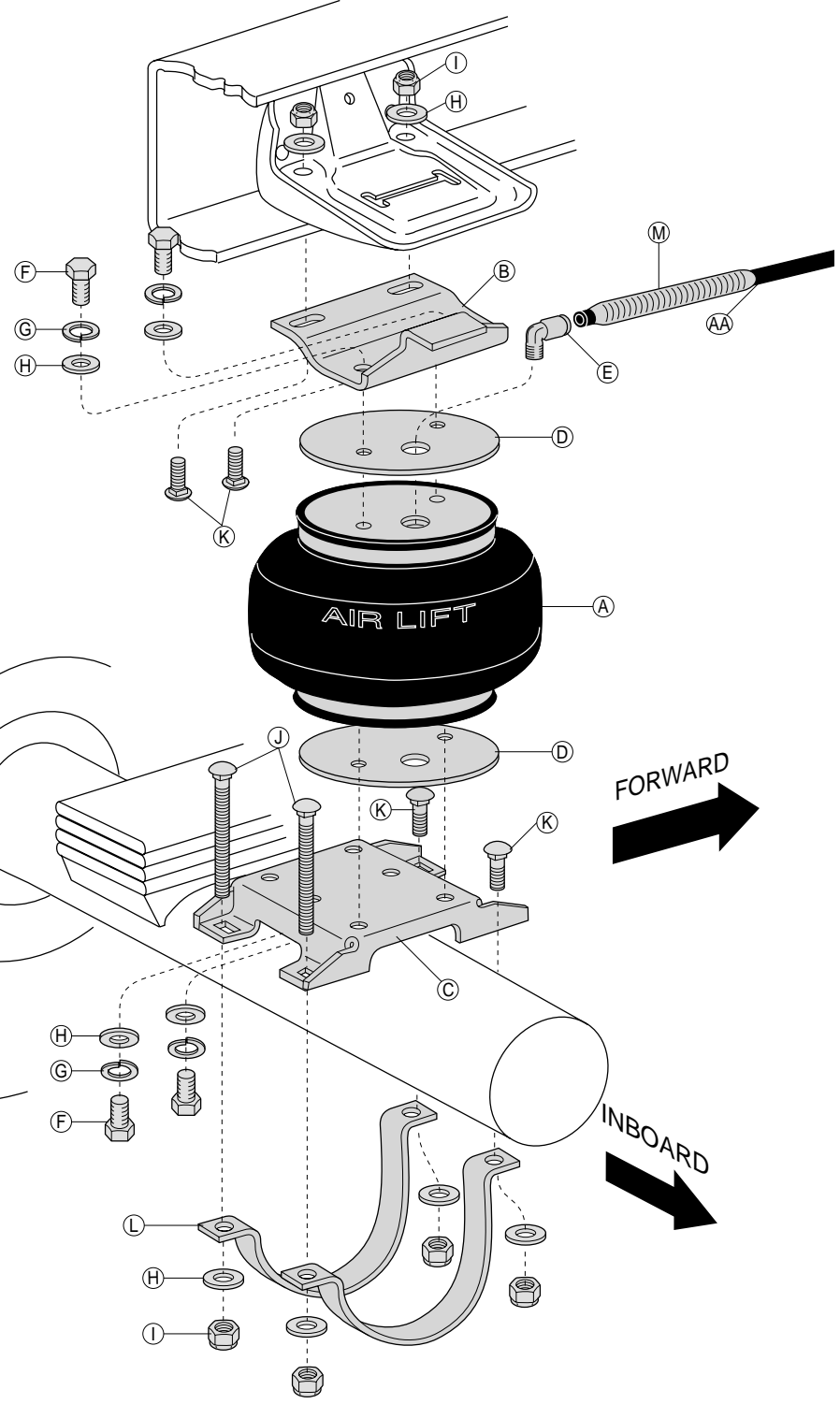

Figure 1

## Tools Needed

$\frac{7}{16}$ " and  $\frac{9}{16}$ " open-end or box wrenches  
Crescent Wrench  
Ratchet with  $\frac{3}{8}$ ",  $\frac{9}{16}$ ", and  $\frac{1}{2}$ " deep well sockets  
 $\frac{3}{8}$ " and  $\frac{5}{16}$ " drill bits (very sharp)  
 $\frac{3}{8}$ " Nut Driver  
Heavy Duty Drill  
Torque Wrench

Hose Cutter, Razor Blade, or Sharp Knife  
Hoist or Floor Jacks  
Safety Stands  
Safety Glasses  
Air Compressor, or Compressed Air Source  
Spray Bottle with Dish Soap/Water Solution

**DANGER:** Compressed air can cause injury and damage to the vehicle and parts if it is not handled properly. For your safety, do not try to inflate the air springs until they have been properly secured to the vehicle.

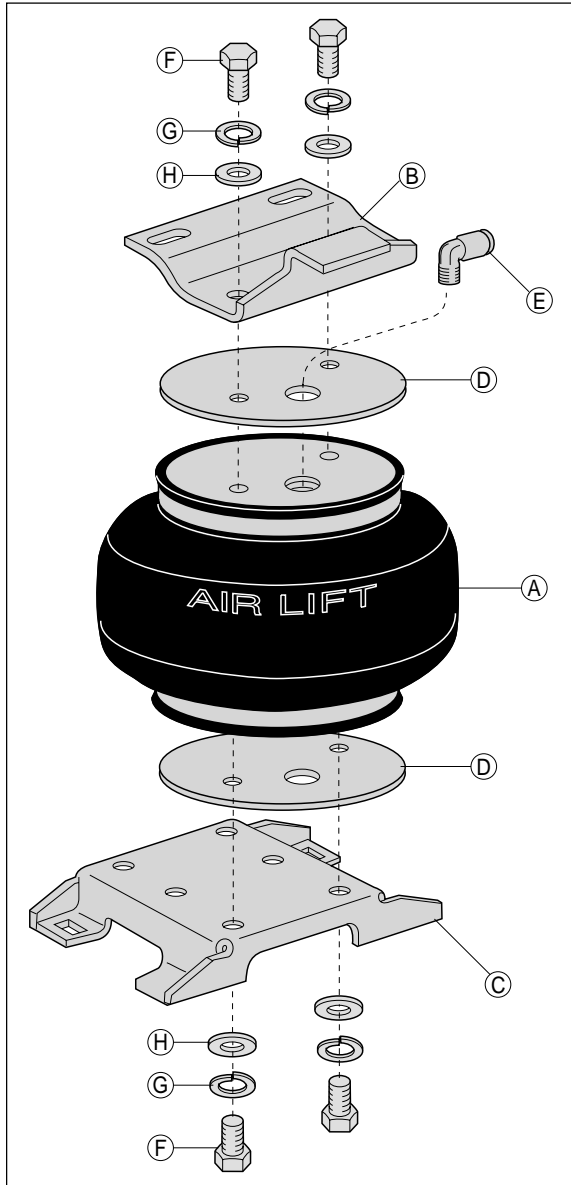

Figure 2

## I. Assembling the Air Spring Assembly

1. Place backer plate (D) on the top of the air spring (A).
2. Install 90° elbow fitting (E) to the top of the air spring. Tighten finger tight plus 1 and  $\frac{1}{2}$  turns. Be careful to only tighten on the metal hex nut. Do not over tighten.
3. Set the upper bracket (B) onto the air spring (A). Make sure that the air fitting port is on the same side as the tab. Attach the bellow-bracket assembly using  $\frac{3}{8}$ " bolt (F),  $\frac{3}{8}$ " lock washer (G), and  $\frac{3}{8}$ " flat washer (H). Tighten to 20 ft-lbs (Figure 2).
4. Set a backer plate (D) onto the bottom of the air spring assembly.
5. Place the lower bracket onto the air spring assembly in an offset position (Figure 2).

*NOTE: The bellows assembly will offset (over hang) the lower bracket. Make sure that the offset is on the air fitting side of the assembly*

6. Use the template provided on page 9 to determine the correct holes for mounting. Use the holes marked by an "A" for bellow mounting.
7. Use a  $\frac{3}{8}$ " bolt (F), a  $\frac{3}{8}$ " lock washer (G), and a  $\frac{3}{8}$ " flat washer (H) through the holes marked with an "A" to attach the lower bracket and backer plate to the assembly. Again, be sure that the bellow is offset to the fitting side. Tighten hardware to 20 ft-lbs (Figure 2).

## II. Attaching the Upper Bracket

1. Use a screwdriver to remove or pry the rubber jounce bumper from the metal bracket on the frame rail (Figure 3). This will not be reused.
2. Remove the two nuts and bolts holding the metal to metal stop to the frame (Figure 4). Discard these parts. Replacement nuts and carriage bolts are provided.
3. It may be necessary to remove the clip holding the lines on the inside of the frame rail to provide access to the existing bolts (Figure 5).
4. Insert two short carriage bolts (K) into the upper bracket (Figure 1).
5. Set the assembly onto the the axle and insert the carriage bolts through the existing holes where the metal-to-metal stop was mounted.

*NOTE: The tab of the upper bracket rests against the jounce bumper bracket. It does not go into the slot (Figure 6).*

6. Secure the upper bracket to the frame and jounce bumper bracket using a flat washer (H) and nylock nut (I) on each carriage bolt (Figure 1).

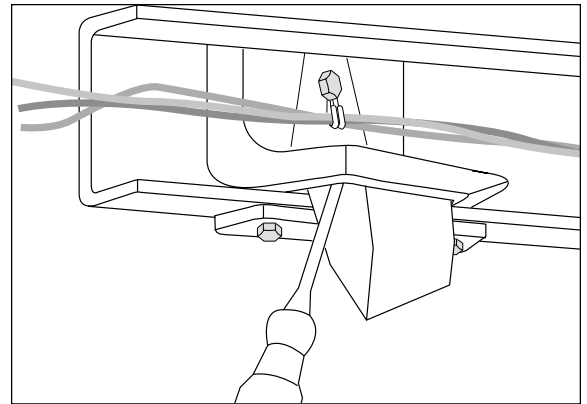

Figure 3

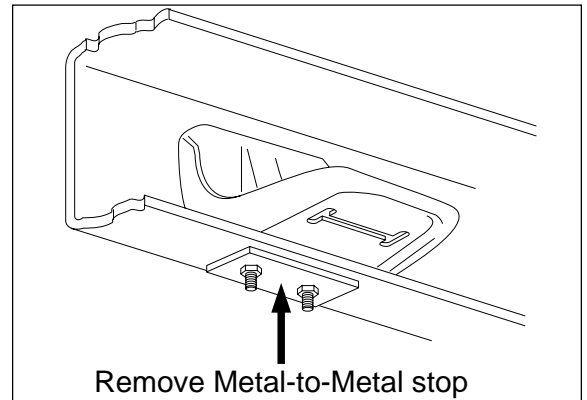

Figure 4

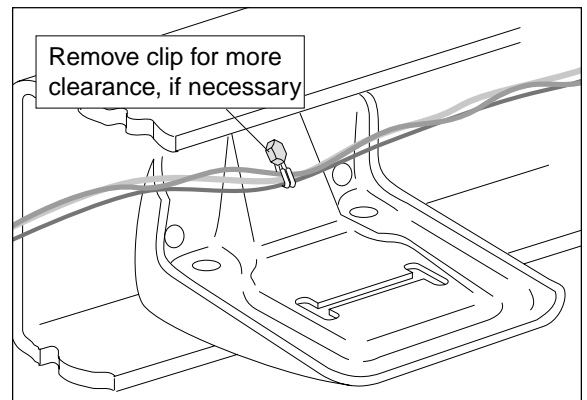

Figure 5

## III. Attaching the Lower Bracket

1. Install two  $\frac{3}{8}$ " x 1.5" carriage bolts (K) in the two *forward* facing holes of the lower bracket (Figure 1).
2. Install two  $\frac{3}{8}$ " x 3.5" carriage bolts (J) in the *rearward* facing holes of the lower bracket (Figure 1).

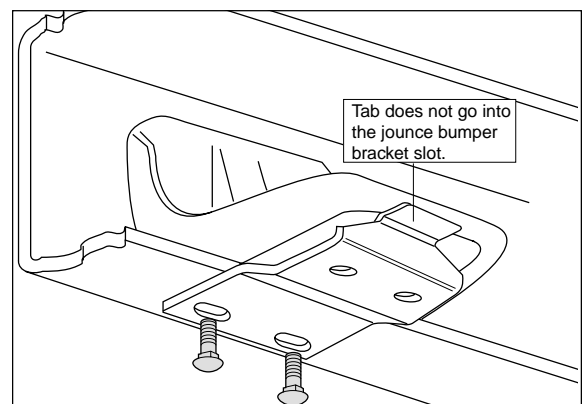

Figure 6

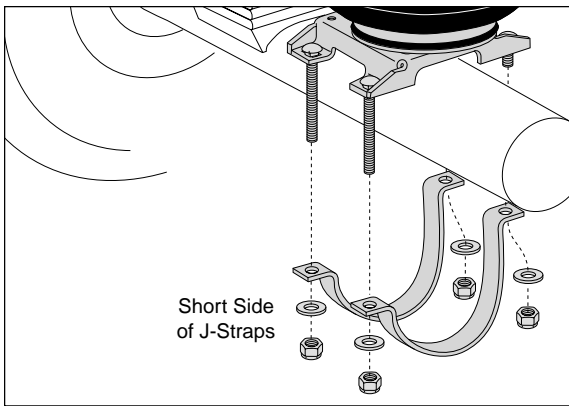

Figure 7

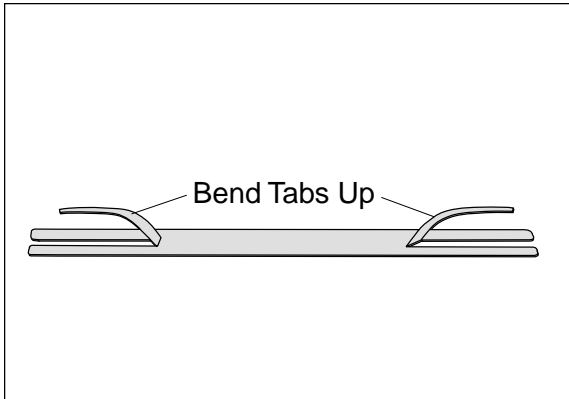

Figure 8

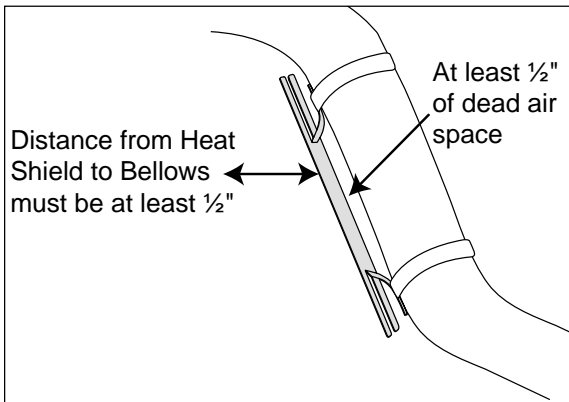

Figure 9

3. Install the J-straps (L) with the *long leg to the front* of the vehicle. Loosely attach the straps using flat washers (H) and  $\frac{3}{8}$ " lock nuts (I). Refer to Figures 1 and 7.
4. On the shock absorber side of the lower bracket, fit the J-strap between the shock bracket and the axle housing. It is not necessary to remove the shock absorber.

*NOTE: Disconnecting the lower shock attachment may simplify the installation, although this is not necessary.*

5. Inspect the assembly and make sure that the bellows is mounted straight up and down and that the lower bracket is centered on the axle housing. The upper bracket is slotted for adjustment.
6. Cross tighten the nuts on the shorter carriage bolts first and then the long bolts. Tighten the J-strap nuts to 16 ft-lbs.
7. Secure the upper bracket to the frame/jounce bumper bracket assembly. Tighten to 20 ft-lbs.
8. Reattach the clip on the lines on the inside of the frame rail using the original hardware.

#### IV. Installing other Air spring

1. Installation for one air spring is now complete. Continue by repeating steps II–III for the other side.
2. Return to step V when second air spring is installed.

#### V. Installing the Heat Shield

1. Bend tabs to provide a  $\frac{1}{2}$ " dead air space between exhaust pipe and heat shield (Figure 8).
2. Attach the heat shield (N) to the exhaust pipe using the provided clamps (O). See Figure 9. Bend the heat shield for maximum clearance to the air spring.

## VI. Installing the Air Lines

1. Choose a convenient location for mounting the inflation valves. Popular locations for the inflation valve are in the wheel well flanges, in the stowage area, under the body flange.

*NOTE: Whatever the chosen location is, make sure there is enough clearance around the inflation valves for an air chuck.*

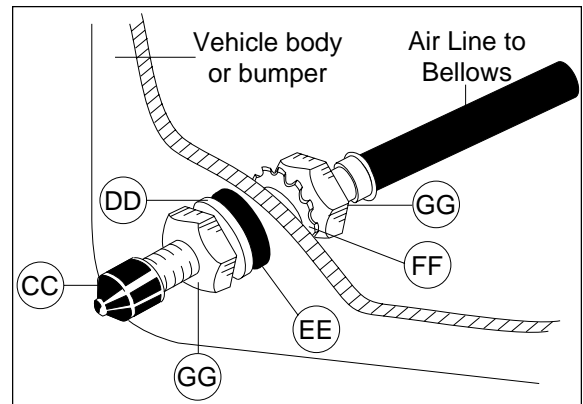

Figure 11

2. Drill a  $\frac{5}{16}$ " hole to install the inflation valves.
3. Cut the air line assembly (AA) in two equal lengths.

*CAUTION: When cutting or trimming the air line, use a hose cutter, a razor blade or a sharp knife. A clean, square cut will ensure against leaks. Do not use wire cutters or scissors to cut the air line. These tools may flatten or crimp the air line, causing it to leak around the O-ring seal inside the elbow fitting.*

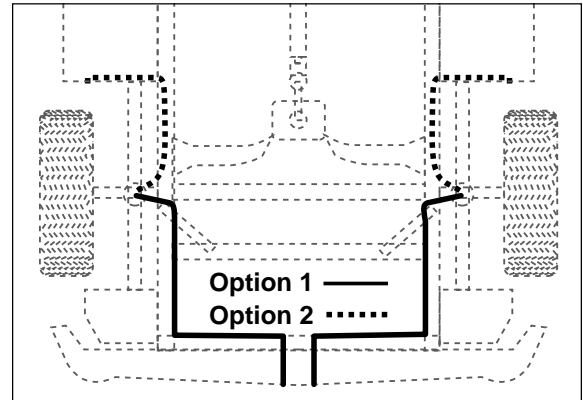

Figure 12

4. Place a  $\frac{5}{16}$ " nut (GG) and a star washer (FF) on the air valve. Leave enough of the valve in front of the nut to extend through the hole and have room for the rubber washer (EE), flat washer (DD), and  $\frac{5}{16}$ " nut (GG) and cap (CC). There should be enough valve exposed after installation - approximately  $\frac{1}{2}$ " - to easily apply a pressure gauge or an air chuck (Figure 11).
5. Push the inflation valve through the hole and use the rubber washer (EE), flat washer (DD), and another  $\frac{5}{16}$ " nut (GG) to secure it in place. Tighten the nuts to secure the assembly in place (Figure 11).
6. Route the air line along the frame to the air fitting on the air spring (Figure 12). Keep at least 6" of clearance between the air line and heat sources, such as the exhaust pipes, muffler, or catalytic converter. Avoid sharp bends and edges. Use the plastic tie straps (BB) to secure the air line to fixed, non-moving points along the chassis. Be sure that the tie straps are tight, but do not pinch the air line. Leave at least 2" of slack to allow for any movement that might pull on the air line.
7. On both sides, place the provided thermal sleeve (M) on the air line near the exhaust.
8. Cut off air line leaving approximately 12" of extra air line. A clean square cut will ensure against leaks. Insert the air line into the air fitting. This is a push to connect fitting. Simply push the air line into the 90° swivel fitting until it bottoms out ( $\frac{9}{16}$ " of air line should be in the fitting).

## VII. Checking for Leaks

1. Inflate the air spring to 60 p.s.i. and spray all connections and the inflation valves with a solution of  $\frac{1}{5}$  liquid dish soap and  $\frac{4}{5}$  water to check for leaks. Leaks will be spotted easily by looking for bubbles in the soapy water.
2. After the test, deflate the springs to the minimum pressure required to restore the Normal Ride Height, but not less than 20 p.s.i.
3. **IMPORTANT:** Check the air pressure again after 24 hours. A 2 to 4 p.s.i. loss after initial installation is normal. Retest for leaks if the loss is more than 5 lbs.

## VIII. Fixing Leaks

1. If there is a problem with the swivel fitting, then:
  - a. Check the air line connection by deflating the spring and removing the line by pulling the collar against the fitting and pulling firmly on the air line. Trim 1" off the end of the air line. Be sure the cut is clean and square. Reinsert the air line into the push-to-connect fitting.
  - b. Check the threaded connection by tightening the swivel fitting another  $\frac{1}{2}$  turn. If it still leaks, deflate the air spring, remove the fitting, and re-coat the threads with thread sealant. Reinstall by hand tightening as much as possible, then use a wrench for an additional two turns.
2. If there is a problem with the inflation valve, then:
  - a. Check the valve core by tightening it with a valve core tool.
  - b. Check the air line connection by removing the air line from the barbed type fitting. **CAUTION: Do not cut it off. As this will usually nick the barb and render the fitting useless.** Cut air line off a few inches in front of the fitting and use a pair of pliers or vise-grips to pull/twist the air line off the fitting.
3. If the preceding steps have did not resolve the problem, call Air Lift Technical Support at 1-800-248-0892 for assistance.

## IX. Troubleshooting Guide

*Problems maintaining air pressure, without on-board compressor.*

1. Leak test air line connections and threaded connection of the elbow into the air spring. See Section VIII to repair.
2. Leak test the inflation valve for leaks at the air line connection or dirt or debris in the valve core. See Section VIII for repair.
3. Inspect air lines to be sure it is not pinched at the tie straps. Loosen or replace strap and replace leaking components.
4. Inspect air line for holes and cracks. Replace as needed.
5. A kink or fold in the air line. Reroute as needed.

*You have now tested for all of the most probable leak conditions that can be easily fixed. At this point the problem is most likely a failed air spring - either a factory defect or an operating problem. Please call Air Lift at 1-800-248-0892 for assistance or a replacement air spring.*

## X. Checklist

You can protect your warranty on this product and prevent unnecessary wear by ensuring the following checks have been made:

### Section I – Installation (To be completed by the installer):

- 1. Clearance Test - Inflate the air springs to 60 p.s.i. and ensure there is at least 1½" clearance around each sleeve from anything that might rub against them. Be sure to check the tire, brake drum, frame, shock absorbers and brake cables.
- 2. Leak Test Before Road Test – Inflate the air springs to 60 p.s.i., check all connections for leaks with a soapy water solution. See page 6 of the manual for tips on how to spot leaks. All leaks must be eliminated before the vehicle is road tested.
- 3. Heat Test – Be sure there is sufficient clearance from heat sources - at least 6" for air springs and air lines. If a heat shield was included in the kit - install it. If there is no heat shield, but one is required, call 1-800-248-0892.
- 4. Fastener Test – Recheck all bolts for proper torque.

#### Torque Guide:

¾" Hex Head Bolts	20 ft-lbs
Carriage Bolt Lock Nuts	20 ft-lbs
J-Strap Lock Nuts	16 ft-lbs

- 5. Road Test – The vehicle should be road tested after the preceding tests. Inflate the springs to 10 p.s.i. or until vehicle is level. Drive the vehicle 10 miles and recheck for clearance, loose fasteners and/or air leaks.
- 6. Operating Instructions – If professionally installed, the installer should review the operating instructions on page 11 with the owner. Be sure to provide the owner with all of the paperwork that came with the kit.

### Section II - Post Installation Checklist (To be completed by the owner):

- 1. Overnight Leakdown Test – Recheck air pressure after vehicle has been used for 24 hours. If pressure has dropped more than 5 p.s.i. then, you have a leak that must be fixed. Either fix the leak yourself (see page 6) or return to the installer for service.
- 2. Air Pressure Requirements – I understand that the air pressure requirements of my air spring system are as follows:

Minimum \_\_\_\_\_ Maximum \_\_\_\_\_

I also understand that I must inflate the air springs until the Ride Height has been restored. Regardless of load, the air pressure should always be adjusted so that the Ride Height is maintained at all times.

- 3. Thirty Day or 500 Mile Test. I understand that I must recheck the air spring system after 30 days or 500 miles, whichever comes first. If any part shows signs of rubbing or abrasion, the source should be identified and moved, if possible. If it is not possible to relocate the cause of the abrasion, the air spring may need to be remounted. If professionally installed, the installer should be consulted. Check all fasteners for tightness.

## XI. Maintenance and Operations

<b>Minimum Air Pressure</b>	<b>Maximum Air Pressure</b>
20 p.s.i.	100 p.s.i.
<b>Minimum Air Pressure for Motorhomes/Commercial Vehicles</b>	
50 p.s.i.	
<i>Failure to maintain correct minimum pressure (or pressure proportional to load), bottoming out, over-extension, or rubbing against another component will void the warranty.</i>	

By following these steps, vehicle owners will obtain the longest life and best results from their air springs.

1. Check the air pressure weekly.
2. Always maintain Normal Ride Height. Never inflate beyond 100 p.s.i.
3. If you develop an air leak in the system, use a soapy water solution to check all air line connections and the inflation valve core before deflating and removing the air spring. (See page 8.)
4. When increasing load, always adjust the air pressure to maintain the Normal Ride Height. Increase or decrease pressure from the system as necessary to attain Normal Ride Height for optimal ride and handling. Remember that loads carried behind the axle (including tongue loads) require more leveling force (pressure) than those carried directly over the axle.
5. **IMPORTANT:** For your safety and to prevent possible damage to your vehicle, *do not exceed maximum Gross Vehicle Weight Rating (GVWR), as indicated by the vehicle manufacturer.* Although your air springs are rated at a maximum inflation pressure of 100 p.s.i., this pressure may represent too great a load on some vehicles. Check your vehicle owners manual and do not exceed the maximum load listed for your vehicle.
6. Always add air to springs in small quantities, checking the pressure frequently. Sleeves require less air volume than a tire and inflate quickly.
7. *Should it become necessary to raise the vehicle by the frame, make sure the system is at minimum pressure (20 p.s.i.) to reduce the tension on the suspension/brake components. Use of on-board leveling systems do not require deflation or disconnection.*

# Lower Bracket Template

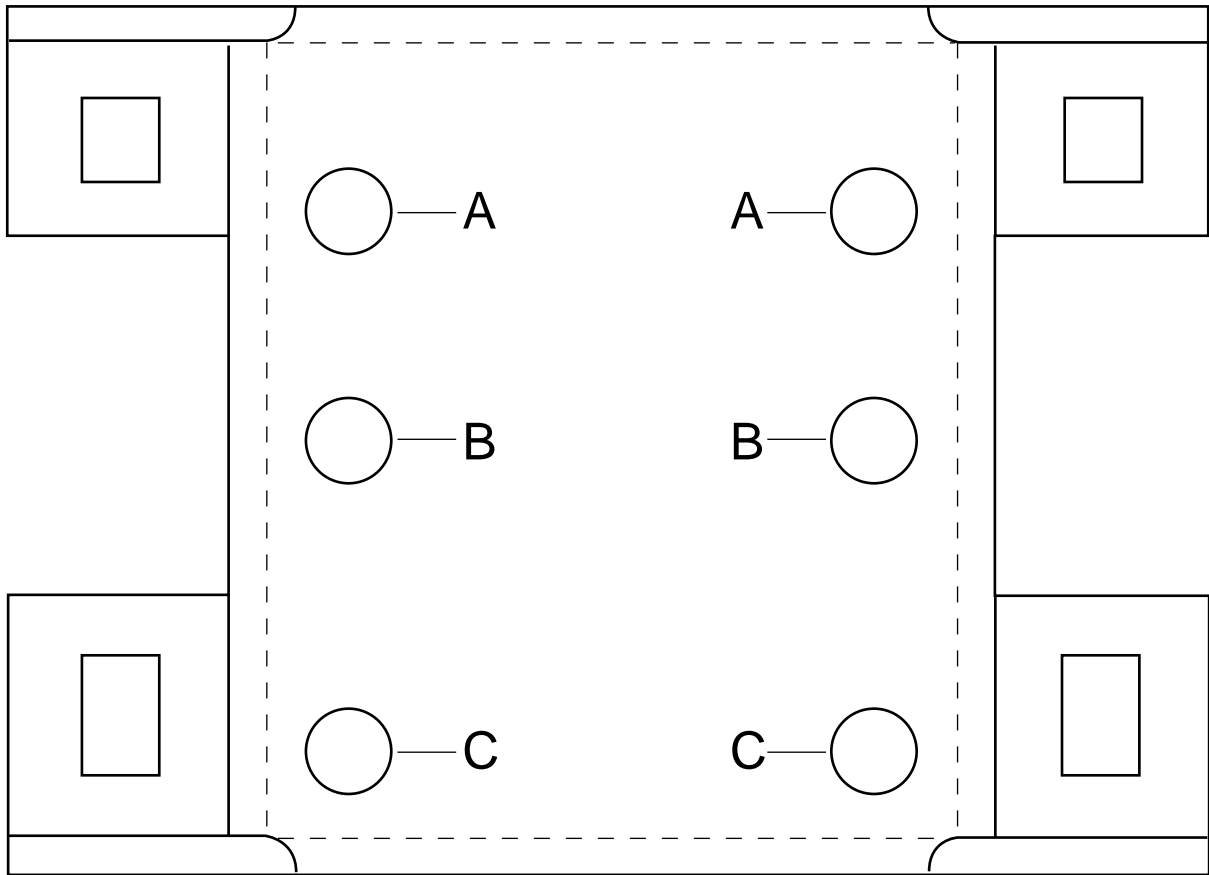



***Thank you for purchasing Air Lift Products***

Mailing Address:  
AIR LIFT COMPANY  
P.O. Box 80167  
Lansing, MI 48908-0167

Street Address:  
AIR LIFT COMPANY  
2727 Snow Rd.  
Lansing, MI 48917

Local Phone: (517) 322-2144

Fax: (517) 322-0240

<http://www.airliftcompany.com>

**For Technical Assistance call 1-800-248-0892**

***“The Choice of the Professional Installer”***

Printed in the USA