

INSTALLATION INSTRUCTIONS DUAL CAM HIGH-PERFORMANCE SWAY CONTROL

Product No.
26102

PLYMOUTH, MI.

DUAL CAM HIGH-PERFORMANCE SWAY CONTROL PROPERLY INSTALLED

(USE ONLY WITH HIGH-PERFORMANCE WEIGHT DISTRIBUTION OR SPRING BARS WITH INTEGRATED CAM, SEE PAGE 2)

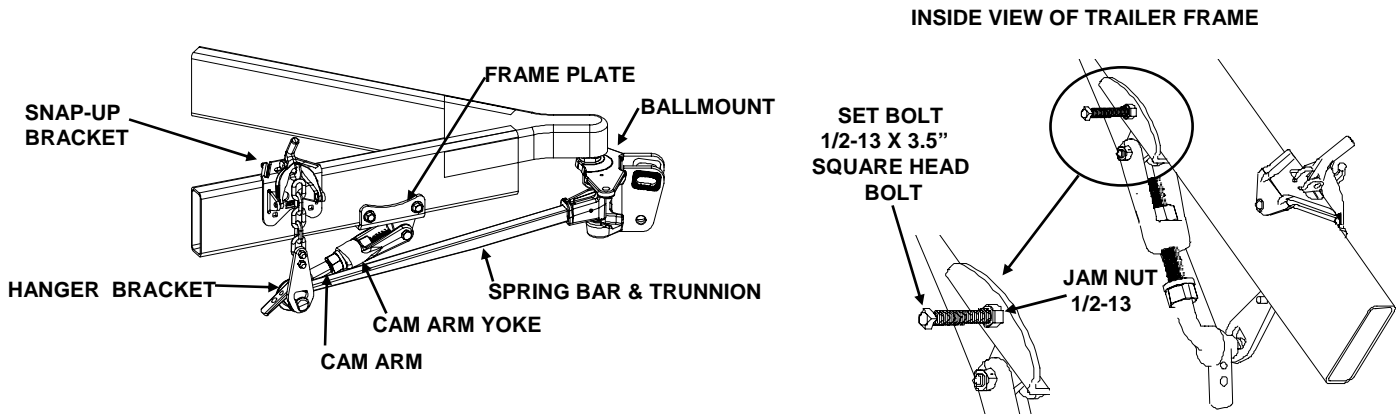

DUAL CAM HIGH-PERFORMANCE SWAY CONTROL COMPONENTS

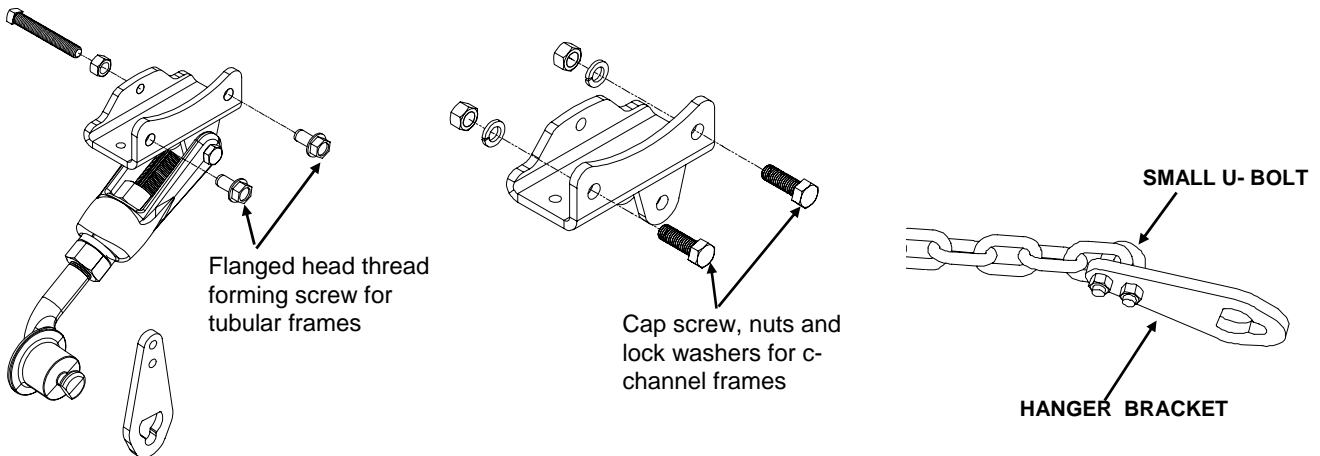

ASSEMBLY:

1. Remove small U-bolt and chain from spring bar if needed. Put the U-bolt in the last chain link, and insert U-bolt ends through two holes in hanger bracket as shown above. Secure with two lock nuts. Make sure that at least two threads are showing past the ends of the nuts, pinch the chain if necessary.
2. Adjust Cam Arm Assembly such that the Cam Arm Yoke is approximately centered on the the Cam Arm threads. Hold position by tightening nuts with finger pressure.

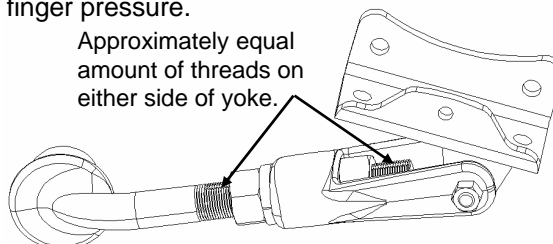

3. Temporarily clamp frame plate on frame with side having two holes outboard and bottom of frame plate in contact with bottom of frame. Position frame plate for reference at a distance of approximately 18" from center of hitch ball socket for **High Performance** spring bars. Frame Plate can be positioned in either position shown to accommodate frame interference. (See figure below.) **It may be necessary to adjust frame plate position on frame for certain coupler and frame combinations.**

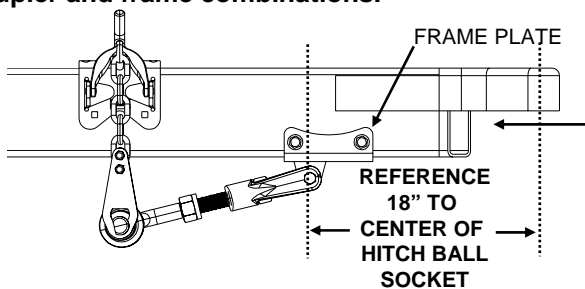

**PREFERRED
FRAME PLATE
ORIENTATION**

**OPTIONAL
FRAME PLATE
ORIENTATION**

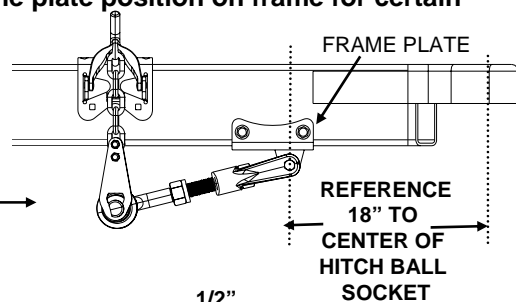

4. Trial fit spring bar in assembly as shown to the right. Confirm that the cam is approximately 1/2" forward of the detent in the spring bar. This will ensure that the cam arm will be approximately in the detent of the spring bar as it is raised by the snap up bracket. **It may be necessary to adjust frame plate position on frame for certain coupler and frame combinations.**

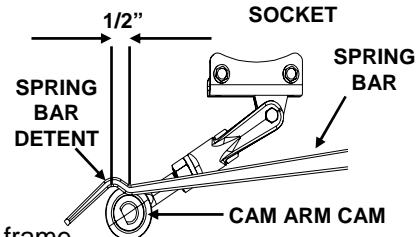

5. Again, make sure bottom of frame plate is in contact with the bottom of the trailer frame.

CAUTION! Before drilling, make sure that there are no obstructions in the trailer frame, such as wiring. Do not drill through opposite wall of frame tube.

FOR TRAILERS WITH TUBULAR FRAMES, DO THE FOLLOWING:

6. Leaving plate on frame, center punch (2) holes. Drill (2) holes to 7/16" diameter. It may be helpful to drill a smaller pilot hole prior to final drilling.

7. Install flanged head, thread forming screws through the frame plate and into the trailer frame. Torque screws to 50 ft-lb.

8. Install jam nut in long set screw. Install long set screw in frame bracket. Tighten set screw until it contacts frame. Then tighten 1/4" turn. (**DO NOT OVER TIGHTEN BOLT**) Tighten jam nut.

9. Repeat steps 1 through 8 for the other side of the frame.

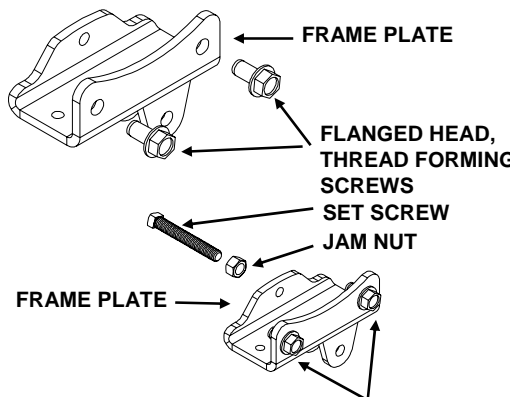

FOR TRAILERS WITH "C" CHANNEL FRAMES, DO THE FOLLOWING:

NOTE: Some "C" channel frames may have square corners that do not allow the frame plate to contact the bottom of the frame. In these scenarios, use a 1/2" flat washer between the side of the frame and the frame plate to maintain contact between the bottom of the frame and the frame plate.

6. Leaving plate on frame, center punch (2) holes. Drill (2) holes to 17/32" diameter. It may be helpful to drill a smaller pilot hole prior to final drilling.

7. Install 1/2-13 x 1.5 cap screws through the frame plate and into the trailer frame. Assemble with lock washers and nuts inside frame. Torque screws to 85 ft-lb.

8. Install jam nut in long set screw. Install long set screw in frame bracket. Tighten set screw until it contacts frame. Then tighten 1/4" turn. (**DO NOT OVER TIGHTEN BOLT**) Tighten jam nut.

9. Repeat steps 1 through 8 for the other side of the frame.

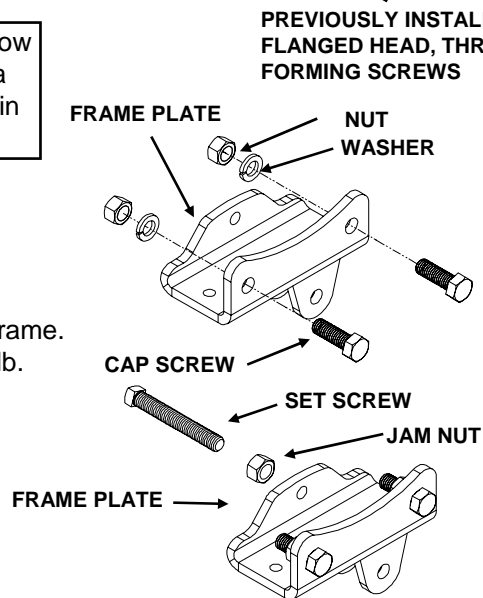

SPRING BAR DETENT

HIGH-PERFORMANCE SPRING BAR



HOOK-UP:

NOTE: Set-up and adjust weight distribution system per Installation Instructions for Weight Distribution. Reference instruction sheet 66006IN for trunnion or 65590IN for round bar styles.

1. Make sure that both cam arm adjustment nuts are backed off sufficiently away from the yoke to allow the cam arm to slide freely through the majority of its adjustment range.
2. Connect trailer to tow vehicle. Tow vehicle and trailer should be in a straight line. Raise trailer tongue and rear of tow vehicle with jack. Install spring bar trunnion in ball mount. Spring bars may be used on either side. Mate spring bar and cam to cam arms. With ends of u-bolt facing inward, slip keyed slot of hanger bracket over button on end of cam arm, rotate to vertical, and pull chain vertical. Place link of chain on hook of snap-up bracket. Make sure that slot of bracket is fully engaged in slot of cam arm.

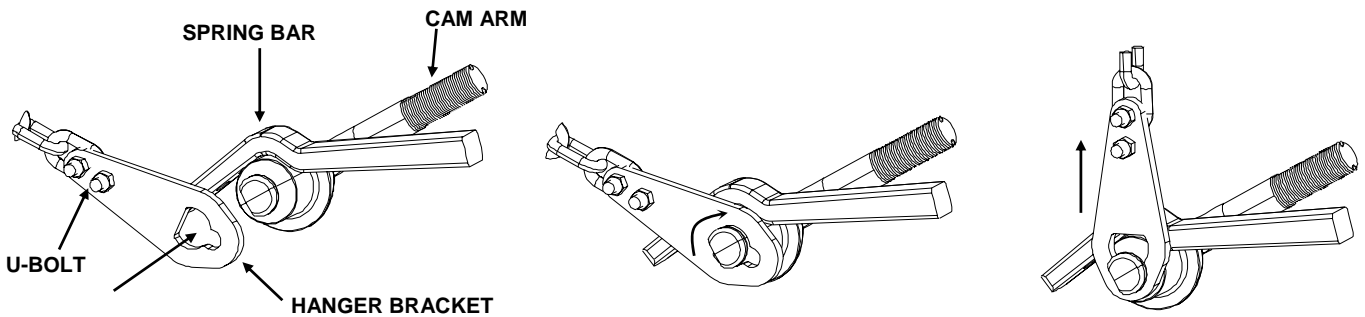

3. Before placing snap-up in position, ensure that the cam of the cam arm is about 1/2" forward of the bend in the spring bar, since the cam moves rearward as it is lifted by the snap-up bracket. After moving snap-up into the up position, install safety pin. Install second spring bar using the same number of chain links. Make sure that cams are mating each other properly.

WARNING! WHILE LIFTING SNAP-UP BRACKET, AND DURING REMAINDER OF SETUP, KEEP HANDS AND FEET AWAY FROM CAM ARM AND UNDER SPRING BARS. COMPONENTS ARE LOADED WITH SUBSTANTIAL FORCE AND COULD SHIFT POSITION OR DROP SUDDENLY CAUSING SERIOUS INJURY.

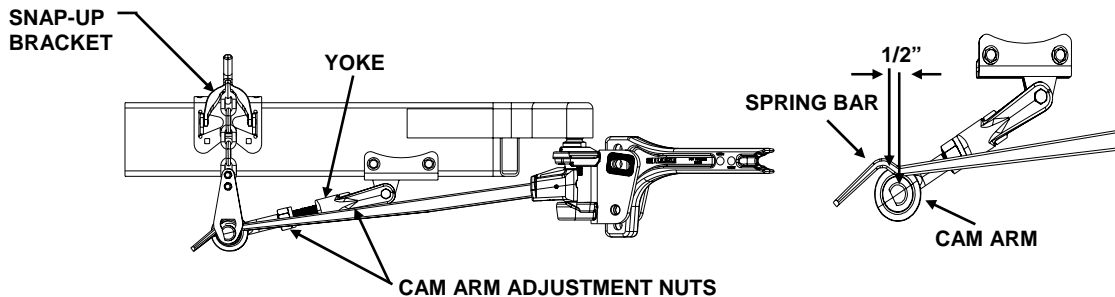

4. Lower jack

CAM ARM ADJUSTMENT:

1. Start out towing slowly in a straight line. Make an approximate 20° turn one way, then a 20° turn the other way. Straighten out and drive approximately 100 ft. toward a distant point while sighting down the center of the hood.

2. Check mating of Integrated Cam with cam arm. If not mated squarely, rap button of cam arm with hammer to obtain alignment (see below).

WARNING! KEEP HANDS AWAY FROM CAM ARM AND YOKE DURING THIS STEP BECAUSE ALIGNMENT MAY OCCUR RAPIDLY, WITHOUT WARNING, CREATING A DANGEROUS PINCH POINT.

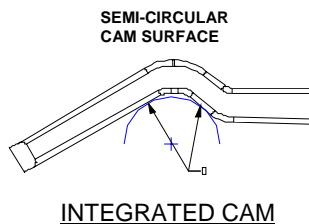
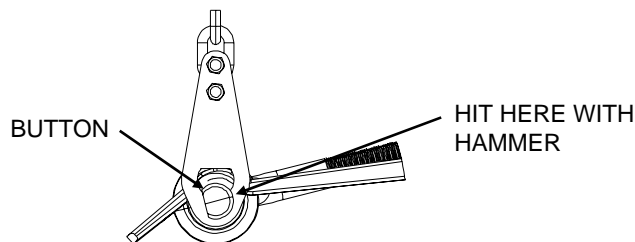

3. Turn cam arm adjustment nut inside cam arm yoke with fingers until it contacts surface of yoke. Turn outside nut with a 1 1/2" wrench tight against yoke to lock adjustment.

4. Repeat Step 3 for the other side.

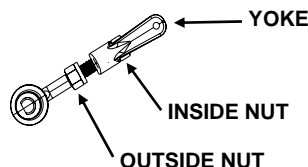

NOTE: From time to time it may be necessary to use a different chain link to properly level tow vehicle and trailer due to weight changes in tow vehicle or trailer, or trunnion wear. Any time a different link is used, the cam arm must be readjusted. Level tow vehicle per Installation Instructions for Weight Distribution. Recheck alignment periodically. 1" Lock washers may need to be replaced after multiple uses.

MAINTENANCE:

1. Do not use grease on cam and cam arms. A light coating vaseline may be used to reduce noise. The Dual Cam was designed to use metal-to-metal friction. Heavy greasing of the cam and cam arm surfaces will affect performance. If noise is offensive, a very light coating of lubricant, such as Vaseline, may be used. Tongue weights over 1,200 lbs., may require a light coating of lubricant to reduce friction and prevent excessive wear.
2. Check for excessive wear on any contact surfaces and replace if necessary.