

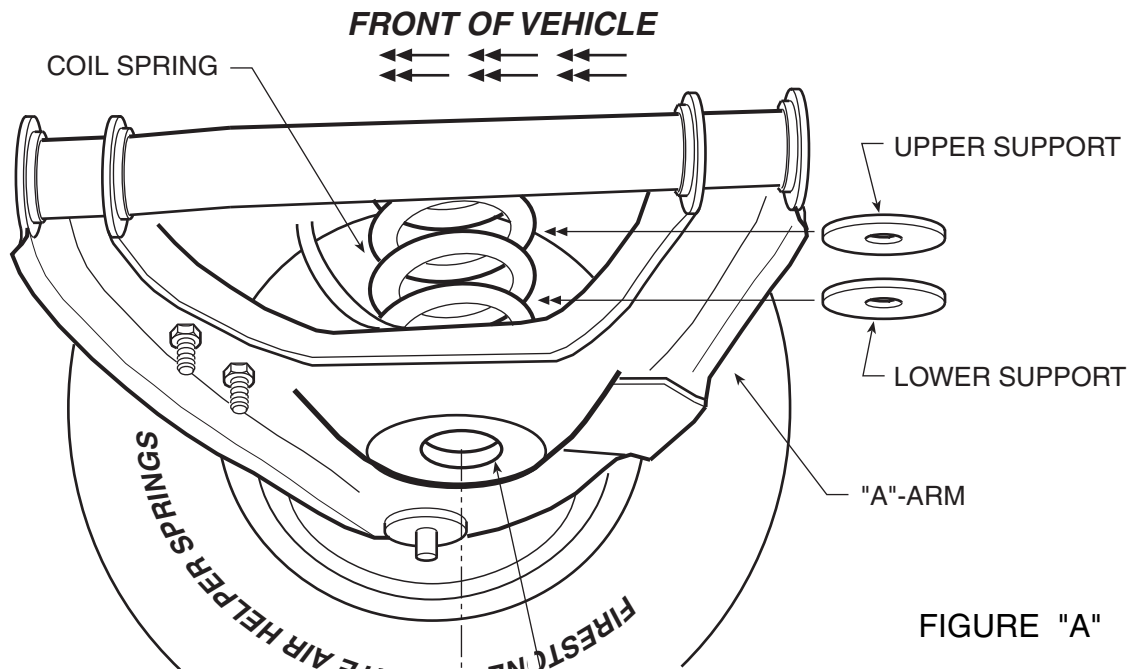

Read installation instructions in its entirety before installing your Coil-Rite Kit

# INSTALLATION INSTRUCTIONS



**Note:** Lubricate the hole in the "A"-arm with a soap solution before inserting the air spring.

PASSENGER'S SIDE



## WARNING

Do not inflate this assembly when it is unrestricted. The assembly must be restricted by a coil spring. Do not inflate beyond recommended operating pressures for your specific vehicle. Improper use or over inflation may cause property damage or severe personal injury.

FIRESTONE INDUSTRIAL PRODUCTS  
CARMEL, INDIANA, USA

### PARTS LIST

DESCRIPTION	QTY.
AIR SPRING	2
SUPPORTS	4
18' AIR LINE	1
NYLON TIE	6
CLIP	2
3/8" -16 x FLANGED LOCK NUT	2
PUSH-TO-CONNECT INFLATION VALVE	2
5/16" FLAT WASHER	4
THERMAL SLEEVE	2

### RECOMMENDED OPERATING PRESSURES

1/2 TON VEHICLES	4 - 45 psi
3/4 TON VEHICLES	10 - 60 psi
GM P-30 10,000 lb. - 15,000 lb. GVWR	40 - 70 psi
GM P-30 16,000 lb. GVWR and up	60 - 90 psi

# COIL-RITE INSTALLATION PROCEDURE

## STEP 1 - PREPARE THE VEHICLE

With the vehicle on a solid level surface, chock the rear wheels. Disconnect the negative battery cable. Raise the front wheels of the vehicle using a lift or platform jack rated for your vehicle's weight. Lower the vehicle frame onto jack stands rated for your vehicle's weight, allowing the suspension to hang freely. (DO NOT use wood or concrete blocks to support the weight of the vehicle.)

## STEP 2 - REMOVE THE EXISTING AIR SPRING

If the vehicle is not equipped with air springs, proceed to Step 3.

Exhaust the air from the air springs completely. Using an electric drill and a 1-1/2" hole saw *without a guide bit*, remove the center portion of the air spring in the hole in the lower A-arm. Lubricate the hole in the lower A-arm with a soap and water solution so that the air spring can easily be pulled through the hole. Pull the air spring through the hole in the A-arm with a pair of vise grips *see Figure "B"*. Remove the existing support located at the top of the coil spring.

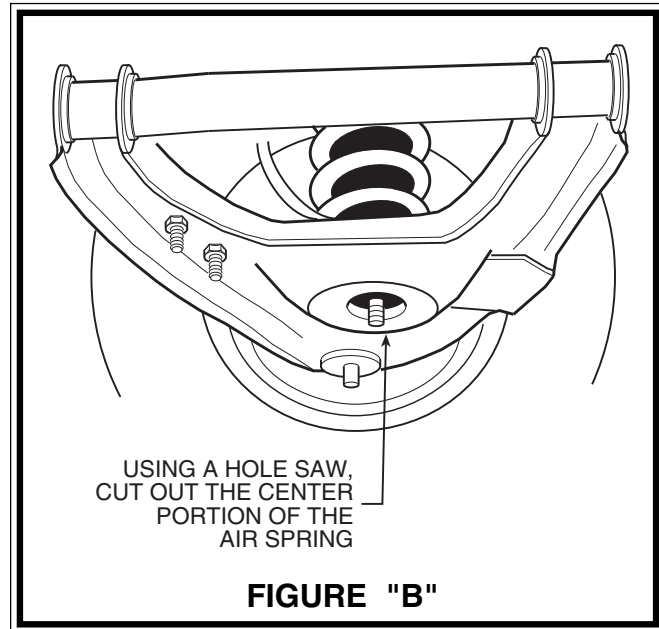

## STEP 3 - PREPARE THE AIR SPRING

Remove the inflation valve cap from the inflation valve on the air spring. Using the valve cap as a core tool, remove the inflation valve core from the air spring. Exhaust the air spring by rolling it tightly. Hold it in the position shown in *Figure "A"*.

## STEP 4 - INSTALL THE AIR SPRING

Insert the air spring into the hole in the lower A-arm so that the air inlet is oriented towards the ground *see Figure "A"*. With the air spring still rolled tightly, work it through the hole in the lower A-arm. Rotate the air spring while pushing it through the hole in the A-arm. Push the air spring completely through the hole. Allow the air spring to expand to its normal shape once inside the coil spring *see Figure "B"*.

Using a blunt tire iron or socket extension, reach through the top of the coil spring and push the air spring downward. Insert the upper support through the coil spring. Place the upper support so that the stud in the upper spring seat inserts into the hole in the upper support *see Figure "A"*.

Install the lower support in the same manner between the bottom of the air spring and the lower spring seat *see Figure "A"*. The hole in the lower support will provide access to allow the inflation valve core to be reinstalled.

Reinstall the inflation valve core in the bottom of the air spring. Use the valve cap to tighten the valve core.

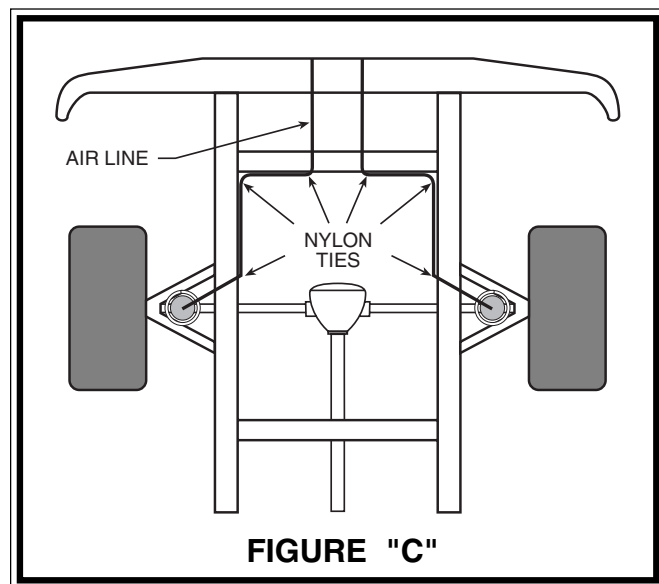

# COIL-RITE INSTALLATION PROCEDURE

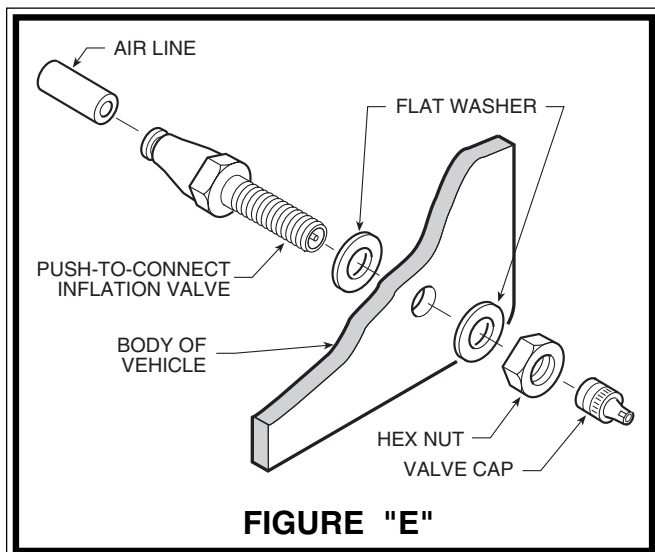
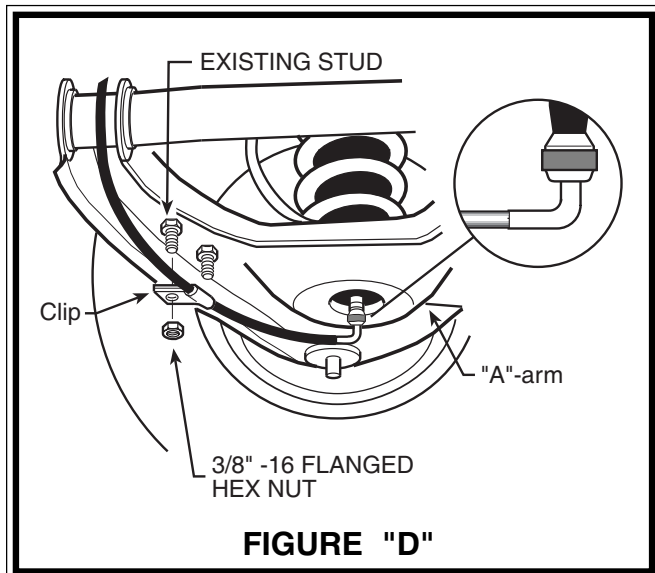

## STEP 5 - ROUTE THE AIR LINE

Cut the air line tubing into two equal lengths, making sure the end is cut squarely (a "saw" cut with a sharp knife is preferred). Route the air line from the air spring to the desired inflation valve location, avoiding direct heat from the exhaust system, radiator, and away from sharp edges *see Figure "C"*. This should be a protected location, such as under the hood or on the bumper. Do not fold or kink the air line tubing. Thread the nut on the elbow fitting onto the air spring (*finger tight*) *see Figure "D"*.

Using the supplied nylon ties, secure the tubing to the vehicle. Attach the air line to the A-arm by installing the supplied clip over the existing stud in the A-arm *see Figure "D"*. Install a 3/8" -16 flanged hex nut onto the stud over the clip. If your vehicle is not equipped with a threaded stud on the A-arm, a 3/8" -16 x 1-1/2" bolt (*not supplied*) can be used.

## STEP 6 - INSTALL THE INFLATION VALVE

Drill a 5/16" hole where you wish to mount the inflation valve. Remember to keep the inflation valve in a protected area that is easily accessible. Attach the inflation valve to the bumper or body of the vehicle *see Figure "E"*.

Cut the excess air line tubing so that it will fit easily into the inflation valve, making sure the end is cut squarely (a "saw" cut with a sharp knife is preferred). Push the end of the tubing into the inflation valve as far as possible.

## STEP 7 - INSTALL THE OPPOSITE-SIDE AIR SPRING

Follow Steps 2-6 to install the second air spring on the remaining side of the vehicle.

## STEP 8 - COMPLETION

This now completes the installation. Jack the vehicle up and remove the jack stands. Reattach the negative battery cable. Remove the wheel chocks from the rear wheels.

## STEP 9 - INFLATE AND TEST

Check the recommended inflation pressure and inflate the air springs to recommended maximum operating pressure (see page 1 for operating pressures). With a soap and water solution, check for air leaks around the fittings and valve core. We recommend inflating and deflating in 5 psi increments to find the ideal riding condition for your vehicle.

**FOR BEST RIDE** use only enough air pressure in the air helper springs to level the vehicle when viewed from the side (front to rear). This amount will vary depending on the load, location of load, condition of existing suspension and personal preference.

**NOTE:** CHECK AIR PRESSURE ON A MONTHLY BASIS.

**FOR MORE INFORMATION OR  
TECHNICAL ASSISTANCE CALL:  
1-800-247-4337**

**Firestone**  
**RIDE-RITE® - COIL-RITE® - SPORT-RITE™**  
*World's Number 1 Air Spring*

*FIRESTONE INDUSTRIAL PRODUCTS  
12650 HAMILTON CROSSING BOULEVARD  
CARMEL, IN 46032*

[www.ride-rite.com](http://www.ride-rite.com)

*TELEPHONE: 317-818-8600  
1-800-247-4337  
FAX: 317-818-8645*