



LEVEL-RITE

Congratulations - your new Air Helper Springs are quality products capable of improving the handling and comfort of your vehicle. As with all products, proper installation is the key to obtaining all of the benefits your kit is capable of delivering. **Please take a few minutes to read through the instructions to identify the components and learn where and how they are used.** It is a good idea to start by comparing the parts in your kit with the parts list below.

Be sure to take all applicable safety precautions during the installation of the kit. The instructions listed in this brochure and the illustrations all show the left, or driver's side of the vehicle. To install the right side assembly simply follow the same procedures.

Your kit includes separate inflation valves and air lines for each air helper spring. This will allow you to level your vehicle from side to side as well as from front to back. If you would rather have a single valve inflation system, your dealer can supply the required "T" fitting.

PARTS LIST

| | | | | | |
|------------------|------|---|-------------------|------|---|
| LEVEL-RITE SHOCK | 7215 | 2 | 5/16" FLAT WASHER | 3033 | 4 |
| UPPER MOUNT | 5604 | 2 | AIR LINE TUBING | 0938 | 1 |
| UPPER BUSHING | 9356 | 2 | STRAIGHT FITTING | 3055 | 2 |
| LOWER BUSHING | | 2 | INFLATION VALVE | 3032 | 2 |
| HEX NUT | | 2 | NYLON TIES | 9036 | 6 |
| FLAT WASHER | | 2 | THERMAL SLEEVES | 0899 | 2 |

IMPORTANT!

DO NOT COMPRESS SHOCK MORE THAN 1 INCH PRIOR TO & DURING INSTALLATION!

For your safety and to prevent possible damage to your vehicle, do not exceed the maximum load recommended by the vehicle manufacturer (GVWR). Although your Air Helper Springs are rated at a maximum inflation pressure of 100 psi, this pressure may allow you to carry too great a load on some vehicles. It is best to have your vehicle weighed once it is completely loaded and compare that weight to the maximum allowed. Check your vehicle owner's manual or data plate on driver's side door for maximum loads listed for your vehicle.

When inflating your Air Helper Springs, add air pressure in small quantities, checking pressure frequently during inflation. The air spring requires much less air volume than a tire and, therefore, inflates much quicker.

STEP 1 - PREPARE VEHICLE

Raise the front of the vehicle and remove the wheels. Place jack stands rated for the weight of the vehicle under the frame just reward of the front axle, lower the vehicle onto the jack stands, and allow the front suspension to extend.

Remove the nut, washer, and upper factory bushing on the top of the factory-style shock. Next, remove the factory installed upper shock mount, nuts, and bushing. These nuts and bushing will be reused. Next, remove the bolt that attaches the bottom of the shock to the lower portion of the suspension. *See Figure "A"*. Once the lower bolt is removed, the existing shock will be removed through the upper spring seat. *See Figure "A"*.

STEP 2 - INSTALLING THE LEVEL-RITE

Install the supplied lower bushing onto the rod of the Level-Rite. Install the straight fitting into the air inlet on the side of the Level-Rite. Tighten the air fitting securely to engage the orange thread sealant. Insert the Level-Rite through the upper spring seat, through the coil, and into the lower spring seat / shock mount. Reinstall the factory hex bolt in the lower shock mount.

Place the supplied upper mount over the Level-Rite and onto studs of the upper spring seat. Reinstall the hex nuts removed from the factory upper shock mount. Next, place the supplied upper bushing and flat washer onto the Level-Rite rod. Install the hex nut and tighten to factory specifications.

SHOCK REMOVAL

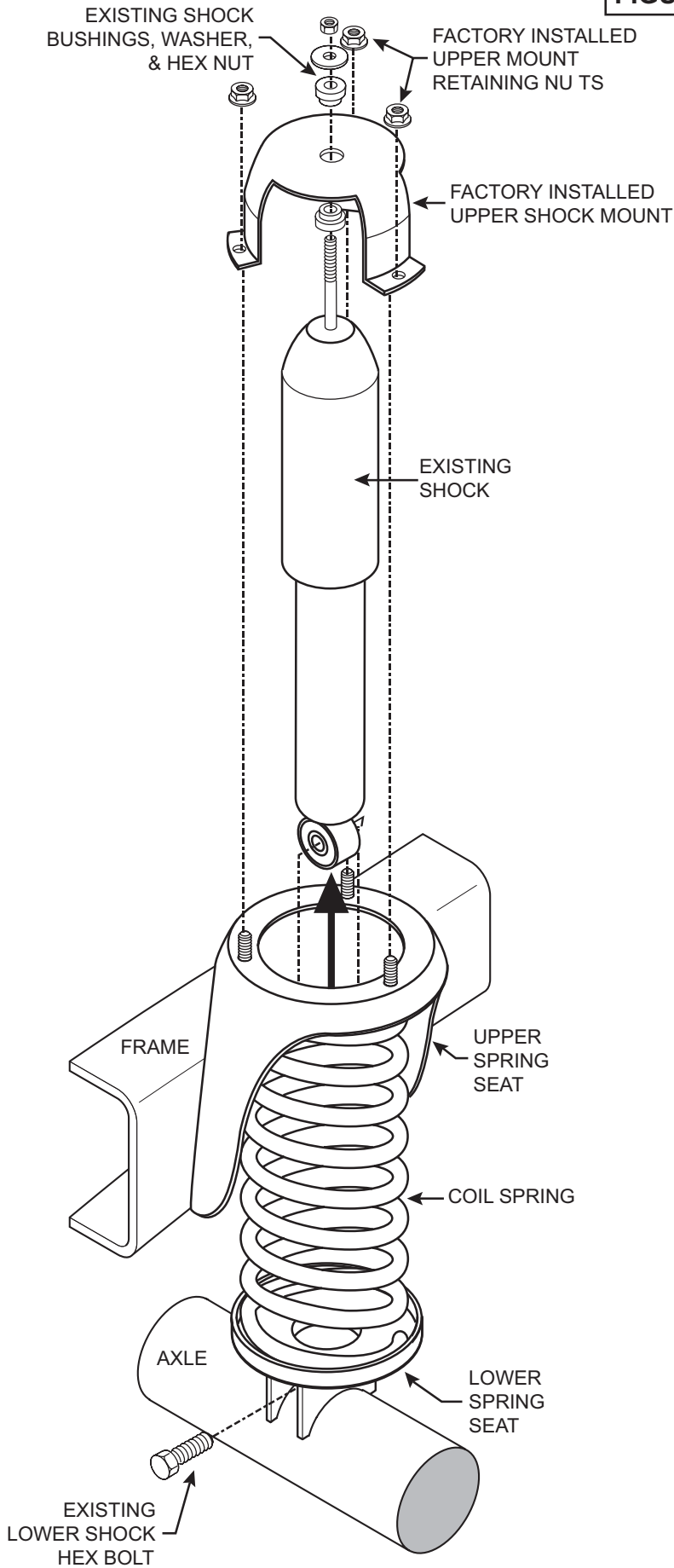
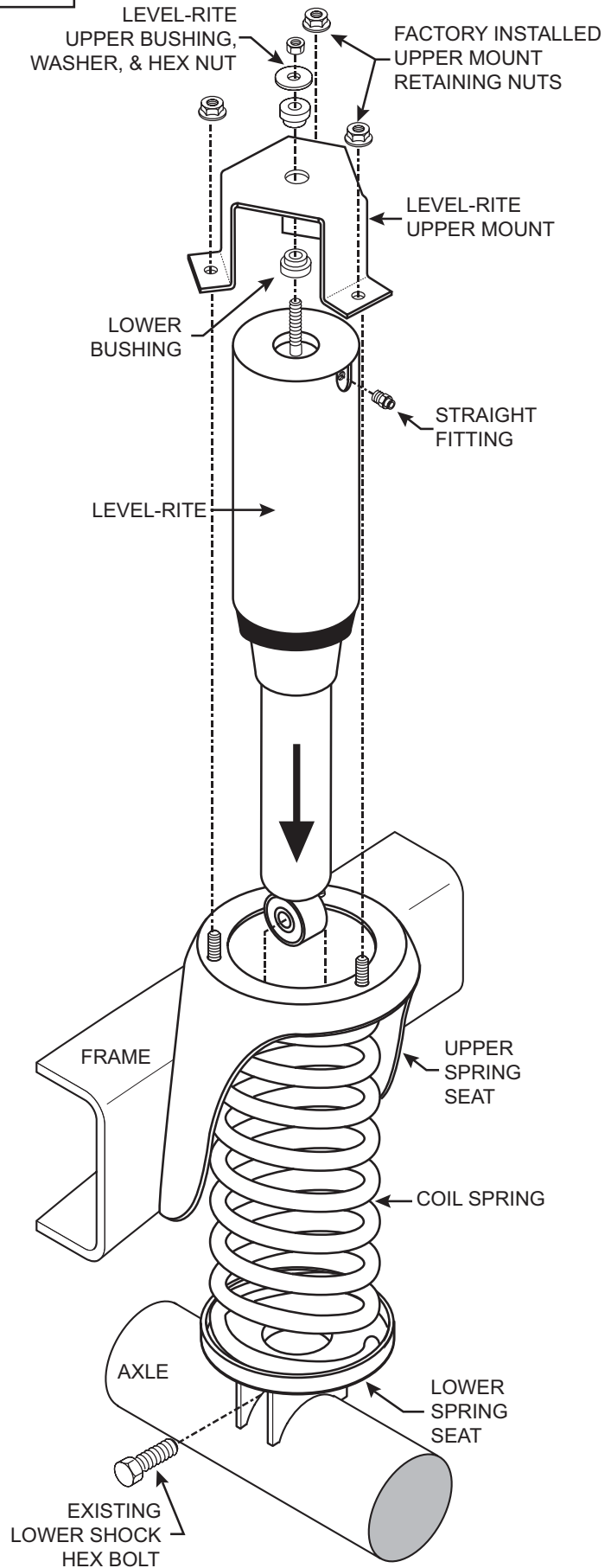
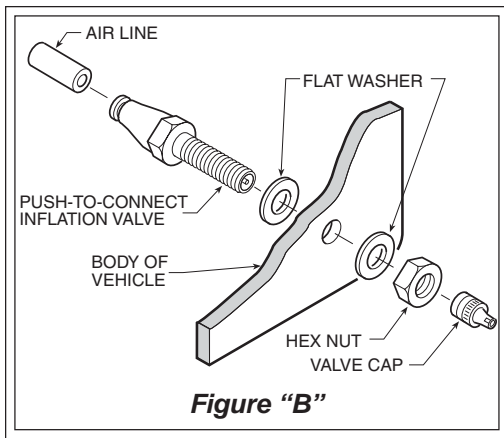

FIGURE "A"

LEVEL-RITE INSTALLATION





STEP 3 - INSTALLING THE AIR LINE AND INFLATION VALVE

Uncoil the air line tubing and cut it into two equal lengths. **DO NOT FOLD OR KINK THE TUBING.** Try to make the cut as square as possible. Insert one end of the tubing into the straight fitting installed into the Level-Rite. Push the tubing into the fitting as far as possible, *see Figure "B"*.

Select a location on the vehicle for the air inflation valves. The location can be on the bumper or the body of the vehicle, as long as it is in a protected location so the valve will not be damaged, but maintain accessibility for the air chuck, *see Figure "C"*. Drill a 5/16" hole and install the air inflation valve using two 5/16" flat washers per valve as supports, *see Figure "C"*. Run the tubing from the air helper spring to the inflation valve, routing it to avoid direct heat from the engine, exhaust pipe, and away from sharp edges. Thermal sleeves have been provided for these conditions. If a thermal sleeve is required simply slide the sleeve over the air line tubing to the location requiring protection. The air line tubing should not be bent or curved sharply as it may buckle. Secure the tubing in place with the nylon ties provided. Push the end of the air line tubing into the inflation valve as illustrated, *see Figure "C"*.

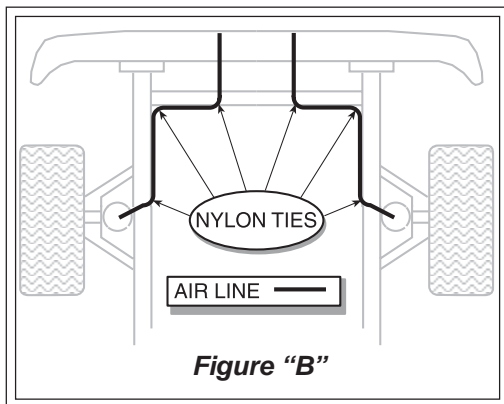

STEP 4 - CHECK THE SYSTEM

Once the inflation valves are installed inflate the Air Over shocks to 70 psi and check the fittings for air leaks with an applied solution of soap and water. If a leak is detected at a tubing connection then check to make sure that the tube is cut as square as possible and that it is pushed completely into the fitting. The tubing can easily be removed from the fittings by pushing the collar towards the body of the fitting and then pulling out the tube. If a leak is detected where the brass fitting screws into the shock, remove the tubing by pushing the collar towards the body of the fitting and then pulling out the tube, then screw the brass fitting into the shock one additional turn. Reinstall the tubing and re-inflate the air springs and check for leaks as noted above.

This now completes the installation. Install the wheels and torque the lug nuts to the manufactures specifications. Raise the front of the vehicle, remove the jack stands, and lower the vehicle back onto the ground. **FOR BEST RIDE** use only enough air pressure in the air helper springs to level the vehicle when viewed from the side (front to rear). This amount will vary depending on the load, location of load, condition of existing suspension and personal preference.

| | |
|------------------------------|----------------|
| NOTE: | |
| MIN PRESSURE | 10 PSI |
| MAX PRESSURE (LOADED) | 100 PSI |

NOTE: DO NOT remove the air spring assembly from the shock. This will cause damage to the product and void the warranty.