**WARNING:**

Do not inflate this assembly when it is unrestricted. The assembly must be restricted by the suspension or other adequate structure. Do not inflate beyond 100 P.S.I. Improper use or over inflation may cause property damage or severe personal injury.

**INSTALLATION INSTRUCTIONS**

Congratulations - your new air helper springs are quality products capable of improving the handling and comfort of your vehicle. As with all products, proper installation is the key to obtaining all of the benefits your kit is capable of delivering. Please take a few minutes to read through the instructions to identify the components and learn where and how they are used. It is a good idea to start by comparing the parts in your kit with the parts list below.

The heart of the kit is, of course, the air helper springs. Remember that the air helper springs must flex and expand during operation, so be sure that there is enough clearance to do so without rubbing against any other part of the vehicle.

Be sure to take all applicable safety precautions during the installation of the kit. The instructions listed in this brochure and the illustrations all show the left, or driver's side of the vehicle. To install the right side assembly simply follow the same procedures.

Your kit includes separate inflation valves and air lines for each air helper spring. This will allow you to level your vehicle from side to side as well as from front to back. If you would rather have a single valve inflation system, your dealer can supply the required T-fitting.

**IMPORTANT!**

*For your safety and to prevent possible damage to your vehicle, do not exceed the maximum load recommended by the vehicle manufacturer (GVWR). Although your Air Helper Springs are rated at a maximum inflation pressure of 100 psi, this pressure may allow you to carry too great a load on some vehicles. It is best to have your vehicle weighed once it is completely loaded and compare that weight to the maximum allowed. Check your vehicle owner's manual or data plate on driver side door for maximum loads listed for your vehicle.*

*When inflating your Air Helper Springs, add air pressure in small quantities, checking pressure frequently during inflation. The air spring requires much less air volume than a tire and, therefore, inflates much quicker.*

**PARTS LIST**

AIR SPRING	6868	2	5/8" -18 NYLON JAM NUT	2
UPPER BRACKET	5539	2	5/16" FLAT WASHER	4
LOWER BRACKET	5540	2	PUSH-TO-CONNECT	
BRACKET CLAMP	5041	2	INFLATION VALVE	2
18 ft. TUBING	0938	1	PUSH-TO-CONNECT	
3/8" -16 x 1-1/2" HEX BOLT		8	STRAIGHT FITTING	2
3/8" -16 x 1/2" FLAT HEAD BOLT		2	THERMAL SLEEVE	2
3/8" -16 x 3-1/2" CARRIAGE BOLT		4	NYLON TIE	6
3/8" -16 FLANGED HEX NUT		12	CAUTION TAG	2

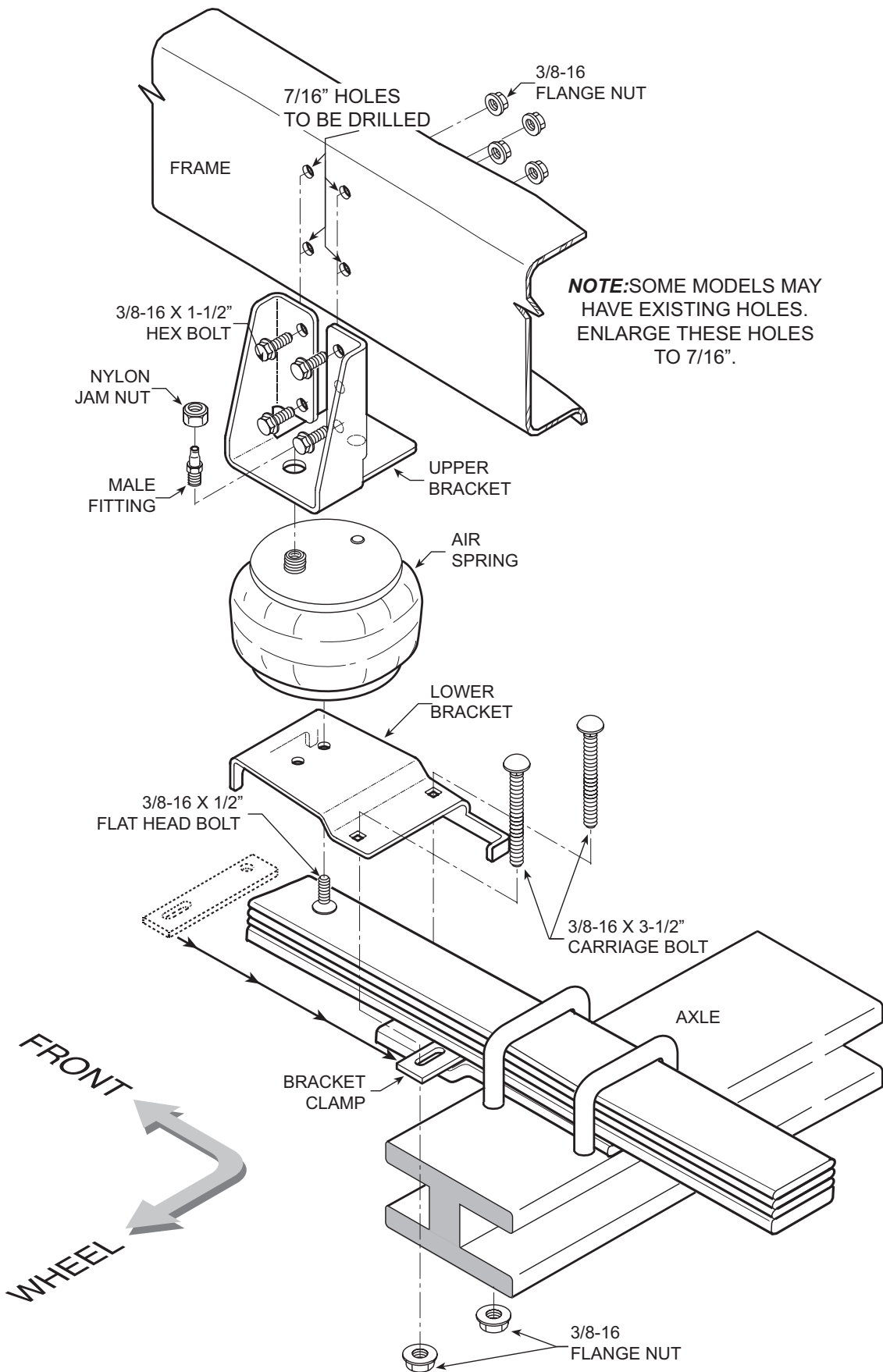

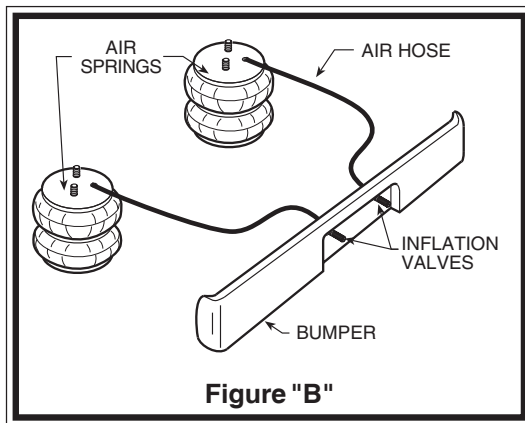

Figure "B"

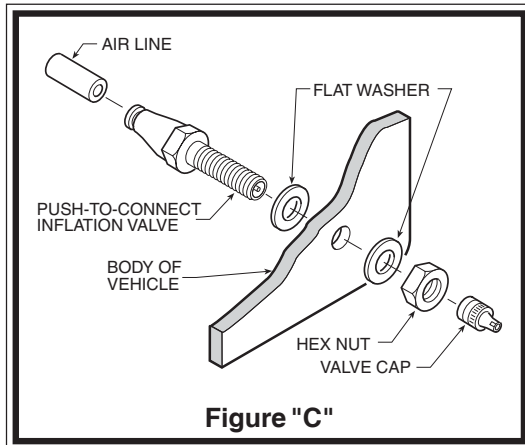

Figure "C"

### STEP 1 - PREPARE THE VEHICLE

With the vehicle on a solid, level surface chock the rear wheels. Raise the vehicle by the front axle and remove the front wheels. After the removal of the wheels, lower the vehicle so that the axle rests on jack stands rated for your vehicle's weight. Remove the negative battery cable.

### STEP 2 - PRE-ASSEMBLE THE KIT

Pre-assembly will begin with the right side of the vehicle. All illustrations show the right side installation and assembly unless noted otherwise.

Select one air spring from the kit. Install the upper bracket by inserting the large stud on the top of the air spring into the large hole in the upper bracket, and the alignment pin on the air spring into the small hole on the upper bracket. *See Figure "A"*. Using the 5/8" - 18 Nylon jam nut, secure the upper bracket to the air spring. Install the air fitting as shown in *Figure "A"*. Tighten the air fitting securely to engage the orange thread sealant. No additional thread sealant is needed. Attach the lower bracket to the bottom of the air spring using the inside hole with a 3/8" - 16 x 1/2" flat head bolt.

### STEP 3 - PRE-FIT AND MARK / DRILL HOLES

Place the assembly on top of the leaf stack forward of the axle. The hook on the lower bracket must capture the leaf spring U-bolt, *see Figure "A"*. Place the upper bracket flush against the frame rail. Using the holes in the bracket as a template, mark the holes to be

drilled with a center punch and remove air spring assembly from the vehicle. On some models, there may be some existing holes that will align with the holes in the upper bracket. These holes will have to be enlarged to 7/16". ***Before drilling, make sure all electrical, brake and fuel lines are cleared from the path of the drill.*** Damage to lines can be avoided by inserting a piece of wood between the frame rail and the lines in question. Drill the four holes in the frame rail using a 7/16" drill bit, *see Figure "A"*.

### STEP 4- INSTALL THE ASSEMBLY TO THE VEHICLE

After drilling the holes in the frame rail, place the air spring assembly back on the leaf stack, making sure that the hook on the lower bracket captures the leaf spring U-bolt. *See Figure "A"*. Install the 3/8" - 16 hex bolts through the mounting holes in the upper bracket and into the frame rail. Fasten the upper bracket to the frame rail using the 3/8" - 16 flanged hex nuts, *see Figure "A"*. Next, attach the lower bracket to the leaf spring assembly. Insert the bracket clamp in between the leaf stack and the sway bar flange below the leaf stack as shown in *Figure "A"*. Insert the 3/8" - 16 x 1-1/2" carriage bolts through the square holes in the lower bracket and into the bracket clamp. *See Figure "A"*. Fasten the bracket clamp to the carriage bolts using the supplied 3/8" - 16 flanged hex nuts.

### STEP 5 - INSTALL THE LEFT SIDE ASSEMBLY

Follow steps 1 - 4 for the assembly and installation of the left side assembly.

### STEP 6 - INSTALL THE AIR LINE AND THE INFLATION VALVES

Uncoil the air line tubing and cut it into two equal lengths. ***DO NOT FOLD OR KINK THE TUBING.*** Try to make the cut as square as possible. Insert one end of the tubing into the fitting installed in the top of the air helper spring. Push the tubing into the fitting as far as possible.

Select a location on the vehicle for the air inflation valves. The location can be on the bumper or the body of the vehicle, as long as it is in a protected location so the valve will not be damaged, but maintain accessibility for the air chuck, *see Figure "B"*. Drill a 5/16" hole and install the air inflation valve using two 5/16" flat washers per valve as supports, *see Figure "C"*. Run the tubing from the air helper spring to the inflation valve, routing it to avoid direct heat from the engine, exhaust pipe, and away from sharp edges. Thermal sleeves have been provided for these conditions.

If a thermal sleeve is required, simply slide the sleeve over the air line tubing to the location requiring protection. The air line tubing should not be bent or curved sharply, as it may buckle. Secure the tubing to the vehicle with the nylon ties provided. Push the end of the air line tubing into the inflation valve as far as possible.

### **STEP 7 - CHECK THE AIR SYSTEM**

Once the inflation valves are installed, inflate the air helper springs to 70 P.S.I. and check the fittings for air leaks with an applied solution of soap and water. If a leak is detected at a tubing connection, check to make sure that the tube is cut as square as possible and that it is pushed completely into the fitting. The tubing can easily be removed from the fittings. First release the air pressure from the air springs. Push the collar towards the body of the fitting and pull out the tube. If a leak is detected where the fitting screws into the spring, screw the fitting into the air spring until the leak stops. Reinstall the tubing and reinflate the air springs and check for leaks as noted above.

This now completes the installation. Install the wheels and torque the lug nuts to the manufacturer's specifications. Raise the vehicle by the front axle and remove the jack stands. Lower the vehicle back to the ground. Reattach the negative battery cable and remove the wheel chocks from the wheels. Before proceeding, check once again to be sure you have proper clearance around the air springs. With a load on your vehicle and the air helper springs inflated, you must have at least 1/2" clearance around the air springs. As a general rule, the air helper springs will support approximately 48 lbs. of load for each P.S.I. of inflation pressure (per pair). For example, 50 P.S.I. of inflation pressure will support a load of 2400 lbs. per pair of air helper springs. *FOR BEST RIDE* use only enough air pressure in the air helper springs to level the vehicle from front to rear, when viewed from the side. This amount will vary depending on the load, location of load, condition of existing suspension and personal preference.

### **NOTE:**

Too much air pressure in the air helper springs will result in a firmer ride, while too little air pressure will allow the air helper spring to bottom out over rough conditions. Too little air pressure will also not provide the improvement in handling that is possible. ***TO PREVENT POSSIBLE DAMAGE, MAINTAIN A MINIMUM OF 5 P.S.I. IN THE AIR HELPER SPRINGS AT ALL TIMES.***

<b>NOTE:</b>	
<b>MIN PRESSURE</b>	<b>5 PSI</b>
<b>MAX PRESSURE (LOADED)</b>	<b>100 PSI</b>

