**WARNING:**

Do not inflate this assembly when it is unrestricted. The assembly must be restricted by the suspension or other adequate structure. Do not inflate beyond 100 psi. Improper use or over inflation may cause property damage or severe personal injury.

INSTALLATION INSTRUCTIONS

Congratulations - your new Air Helper Springs are quality products capable of improving the handling and comfort of your vehicle. As with all products, proper installation is the key to obtaining all of the benefits your kit is capable of delivering. **Please take a few minutes to read through the instructions to identify the components and learn where and how they are used.** It is a good idea to start by comparing the parts in your kit with the parts list below.

The heart of the air helper spring kit is, of course, the air springs. Remember that the air helper springs must flex and expand during operation, so be sure that there is enough clearance to do so without rubbing against any other part of the vehicle.

Be sure to take all applicable safety precautions during the installation of the kit. The instructions listed in this brochure and the illustrations all show the left, or driver's side of the vehicle. To install the right side assembly simply follow the same procedures.

Your kit includes separate inflation valves and air lines for each air helper spring. This will allow you to level your vehicle from side to side as well as from front to back. If you would rather have a single valve inflation system, your dealer can supply the required "T" fitting.

IMPORTANT!

For your safety and to prevent possible damage to your vehicle, do not exceed the maximum load recommended by the vehicle manufacturer (GVWR). Although your Air Helper Springs are rated at a maximum inflation pressure of 100 psi, this pressure may allow you to carry too great a load on some vehicles. It is best to have your vehicle weighed once it is completely loaded and compare that weight to the maximum allowed. Check your vehicle owner's manual or data plate on driver's side door for maximum loads listed for your vehicle.

When inflating your Air Helper Springs, add air pressure in small quantities, checking pressure frequently during inflation. The air spring requires much less air volume than a tire and, therefore, inflates much quicker.

PARTS LIST

224C AIR SPRING	6873	2	3/8" LARGE FLAT WASHER	4
UPPER BRACKETS	5431	2	5/16" FLAT WASHER	4
LOWER BRACKETS	5218	2	PUSH TO CONNECT	
BRACKET STRAPS	5086	2	INFLATION VALVE	3032 2
AIR LINE TUBING		1	PUSH TO CONNECT	
3/8"-16 FLANGE NUT		12	ELBOW FITTING	3031 2
3/8"-16 X 3/4" HEX BOLT		2	THERMAL SLEEVE	2
3/8"-16 X 1 1/2" HEX BOLT		4	NYLON TIE	6
3/8"-16 x 4" CARRIAGE BOLTS		4		

2363

KIT PRE-ASSEMBLY

UPPER BRACKET

3/8" -16
FLANGED
LOCK NUT

AIR FITTING

AIR SPRING

NOTE: Both illustrations are of the left, or drivers side, of the vehicle. Reverse any orientations when assembling and installing the right, or passenger, side of the vehicle.

3/8" -16 x 4"
CARRIAGE BOLT

LOWER BRACKET

3/8" -16 x 3/4"
HEX HEAD BOLT

3/8" -16 x 1 1/2"
FLANGED
HEX BOLT

FRAME

3/8" LARGE
FLAT WASHERS

3/8" -16
FLANGED
LOCK NUT

KIT TO FRAME ASSEMBLY

3/8" -16 x 4"
CARRIAGE BOLT

AXLE

BRACKET STRAP

3/8" -16
FLANGED
LOCK NUT

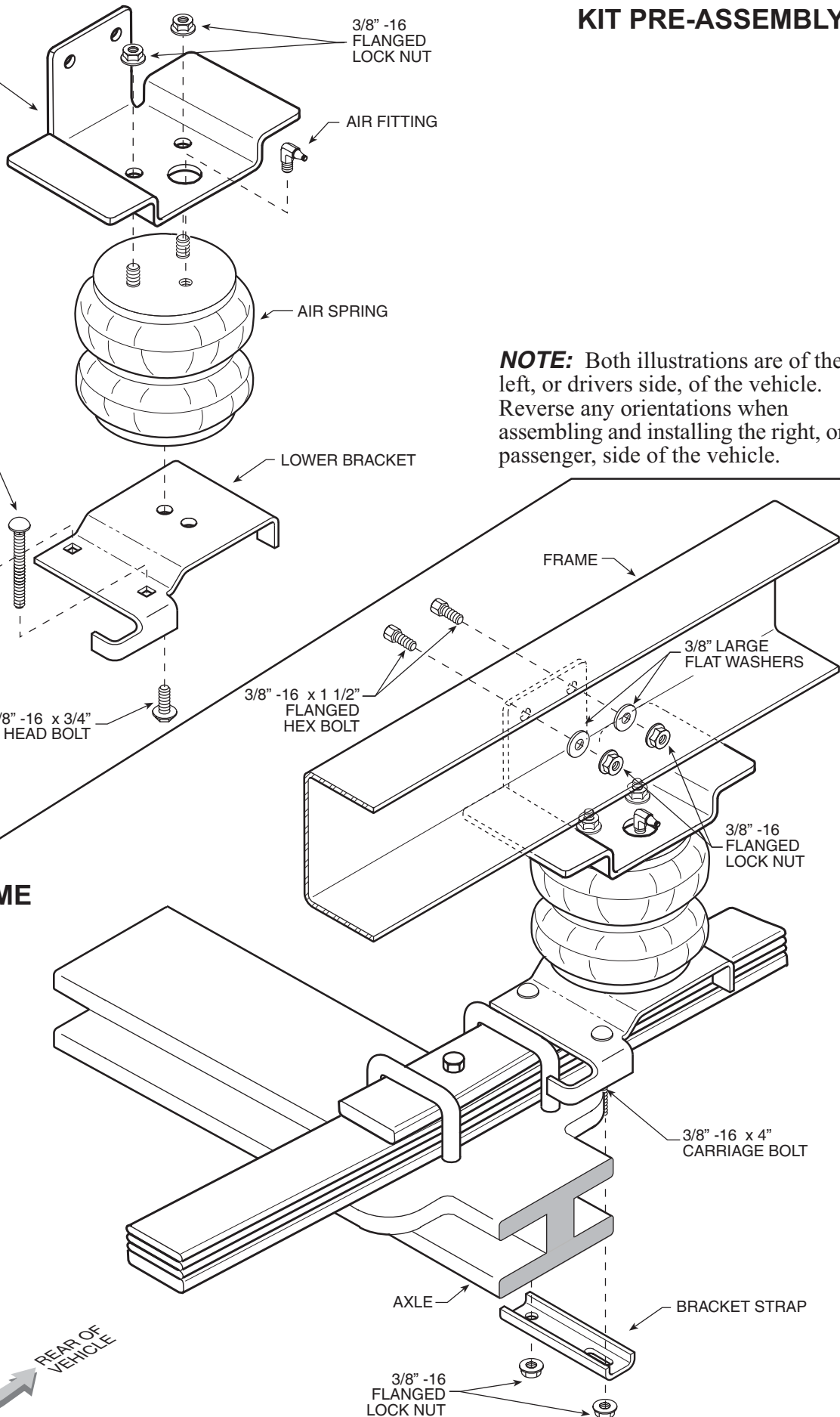

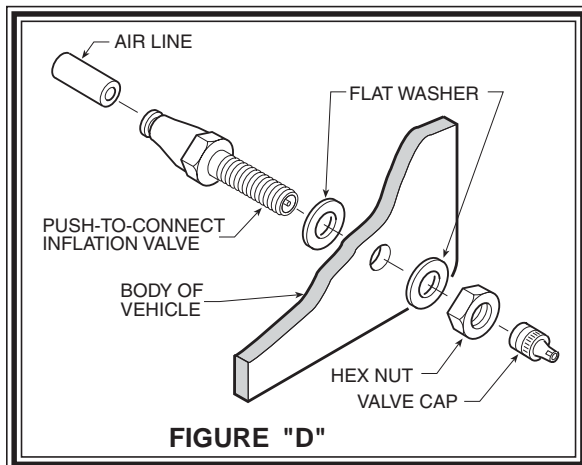
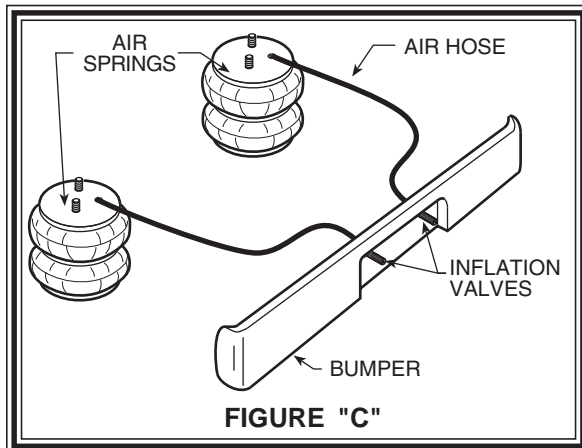
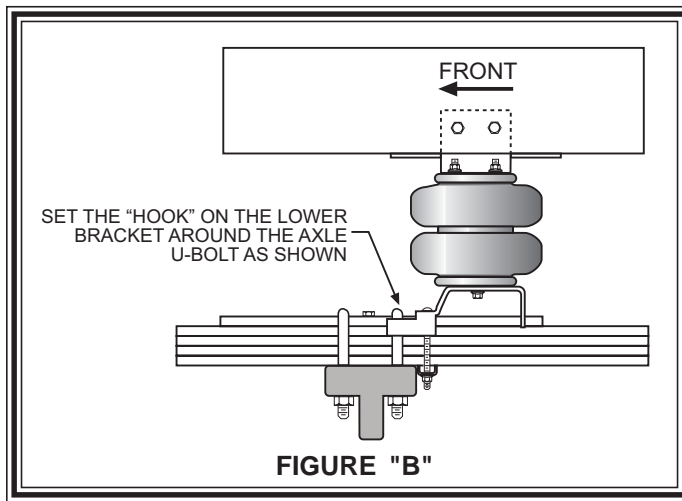

NOTE:

Please read through this manual completely before installing the air spring kit to your vehicle.

STEP 1 – PREPARE THE VEHICLE

This kit can be installed without removing the front wheels. Chock the wheels for safety before working under the vehicle. Remove the negative battery cable.

STEP 2 – PRE-ASSEMBLE THE KIT

Select one air helper spring from your kit. Install the upper bracket by inserting the air helper spring studs into the holes, use two 3/8"-16 flange lock nuts to secure the bracket to the air spring, *see Figure "A"*. Install the air fitting as shown in *Figure "A"*.

Tighten the air fitting securely to engage the orange thread sealant. Position the elbow so as to point in the anticipated location of the air inflation valve, *see Figures "A" and "C"*. Insert the two 3/8"-16 x 4" carriage bolts into the lower bracket. Fasten the lower bracket to the air helper spring using a 3/8"-16 x 3/4" hex bolt, refer to *Figure "A"* for proper orientation of the lower bracket.

STEP 3 – INSTALLING THE ASSEMBLY TO THE VEHICLE

Place the assembly on the driver's side on top of the leaf spring behind the axle; *see Figures "A" and "B"*. Using the upper bracket as a template, drill two 3/8" holes. ***Before drilling the holes make sure all electrical, brake and fuel lines are cleared from the path of the drill.*** Attach the upper bracket with two 3/8"-16 x 1/1/2" hex bolts, 3/8" large washers and 3/8"-16 flange lock nuts. Attach the lower bracket to the leaf spring using a bracket clamp and 3/8"-16 flange lock nuts and the carriage bolts previously installed, *see Figure "A"*. Once the assembly is in place, you must have a minimum of 1/2" clearance around the air spring for proper operation.

STEP 4 – INSTALLATION TO THE PASSENGER'S SIDE ASSEMBLY

Reverse any orientations when assembling and installing the right, or passenger's side of the vehicle.

STEP 5 – INSTALL THE AIR LINE AND INFLATION VALVE

Uncoil the air line and cut it into two equal lengths. **DO NOT FOLD OR KINK THE TUBING.** Try to make the cut as square as possible. Insert one end of the air line into the elbow fitting installed in the top of the air helper spring. Push the tubing into the fitting as far as possible; *see Figure "A"*.

Select a location on the vehicle for the air inflation valves. The location can be on the bumper or the body of the vehicle, as long as it is in a protected location so the valve will not be damaged, but maintain accessibility for the air chuck, *see Figure "C"*. Drill a 5/16" hole and install the air inflation valve using two 5/16" flat washers per valve as supports; *see Figure "D"*. Run the air line from the air helper spring to the valve, routing it to avoid direct heat from the engine, exhaust pipe, and away from sharp edges.

Thermal sleeves have been provided for these conditions. The air line tubing should not be bent or curved sharply as it may buckle. Secure the air line in place with the nylon ties provided. Push the end of the air line into the inflation valve as illustrated; see *Figure “D”*.

STEP 6 – CHECK THE AIR SYSTEM

Once the inflation valves are installed inflate the air helper springs to 70 psi and check the fittings for air leaks with an applied solution of soap and water. If a leak is detected at a air line connection then check to make sure that the air line is cut as square as possible and that it is pushed completely into the fitting. The tubing can easily be removed from the fittings by pushing the collar toward the body of the fitting and then pulling out the tube. If a leak is detected where the brass elbow fitting screws into the spring, remove the air line, then screw the elbow fitting into the spring one additional turn or until the leak stops. Reinstall the air line and re-inflate the air springs and check for leaks as noted above.

This now completes the installation. Re-attach the negative battery cable and remove the wheel chocks from the front wheels. Check again to be sure you have the proper clearance around the air springs. With a load on your vehicle and the air helper springs inflated, you must have at least ½” clearance around the air springs. As a general rule, the Air Helper Springs will support approximately 50 pounds of load for each psi of inflation pressure (per pair). For example, 50 psi of inflation pressure will support a load of 2500 pounds per pair of air helper springs. **FOR BEST RIDE** use only enough air pressure in the air helper springs to level the vehicle when viewed from the side (front to rear). This amount will vary depending on the load, location of load, condition of existing suspension and personal preference.

NOTE:

Too much air pressure in the Air Helper Springs will result in a firmer ride, while too little air pressure will allow the Air Helper Spring to bottom out over rough conditions. Too little air pressure will also not provide the improvement in handling that is possible. **TO PREVENT POSSIBLE DAMAGE MAINTAIN A MINIMUM OF 10 PSI IN THE AIR HELP SPRINGS AT ALL TIMES.**

NOTE:

Once the air helper springs are installed, it is recommended that the vehicles not be lifted by the frame, as over-extension may occur, resulting in damage to the air helper springs. However, should it become necessary to raise the vehicle by the frame, deflate both air helper springs completely.

