

**WARNING:**

Do not inflate this assembly when it is unrestricted. The assembly must be restricted by the suspension or other adequate structure. Do not inflate beyond 100 psi. Improper use or over inflation may cause property damage or severe personal injury.

*The air springs in this kit have a minimum pressure of 5 psi and maximum of 100 psi after the truck is loaded.*

**INSTALLATION INSTRUCTIONS**

Congratulations—your new Air Helper Springs are quality products capable of improving the handling and comfort of your vehicle. As with all products, proper installation is the key to obtaining all of the benefits your kit is capable of delivering. **Please take a few minutes to read through the instructions to identify the components and learn where and how they are used.** It is a good idea to start by comparing the parts in your kit with the parts list below.

The heart of the air helper spring kit is, of course, the air springs. Remember that the air helper springs must flex and expand during operation, so be sure that there is enough clearance to do so without rubbing against any other part of the vehicle.

Be sure to take all applicable safety precautions during the installation of the kit. The instructions listed in this brochure and the illustrations all show the left, or driver's side of the vehicle. To install the right side assembly simply follow the same procedures.

Your kit includes separate inflation valves and air lines for each air helper spring. This will allow you to level your vehicle from side to side as well as from front to back. If you would rather have a single valve inflation system, your dealer can supply the optional "T" fitting.

**IMPORTANT!**

**For your safety and to prevent possible damage to your vehicle, do not exceed the maximum load recommended by the vehicle manufacturer (GVWR).** Although your Air Helper Springs are rated at a maximum inflation pressure of 100 psi, this pressure may allow you to carry too great a load on some vehicles. It is best to have your vehicle weighed once it is completely loaded and compare that weight to the maximum allowed. Check your vehicle owner's manual or data plate on driver's side door for maximum loads listed for your vehicle.

When inflating your Air Helper Springs, add air pressure in small quantities, checking pressure frequently during inflation. The air spring requires much less air volume than a tire and, therefore, inflates much quicker.

Remove the negative battery cable. It is not necessary to jack up the truck to install this Ride-Rite kit, if you do, please use chocks in front of the front tires. Also, use jack stands beneath the truck's rear axle that are properly rated to support the trucks weight.

**PARTS LIST**

224C AIR SPRING	6401	2
UPPER BRACKET	5572	2
LOWER BRACKET	5380	2
SADDLE BRACKET	5379	2
FUEL LINE BRACKET	5428	1
AXLE STRAP	1163	2
1/2" SPACER	5477	2
HEAT SHIELD	1004	1
BAIL CLAMP	3077	2
AIR TUBING		1
THERMAL SLEEVE		2
CAUTION TAG		2
TIE-WRAP		6
5/16"-24 X 3/4" HEX HEAD BOLT		1
5/16"-24 FLANGE HEAD NUT		1
5/16" FLAT WASHER		4

**HARDWARE PACK (A21-760-2550)**

3/8"-16 X 3/4" FLANGE HEAD BOLT	2
3/8"-16 X 1" HEX HEAD BOLT	8
3/8"-16 X 2-1/2" FLAT HEAD BOLT	2
3/8"-16 X 3" CARRIAGE BOLT	4
3/8"-16 FLANGE HEAD NUT	18
3/8" LARGE FLAT WASHER	2
3/4"-16 X 3" HEX HEAD BOLT	2
3/4"-16 X 1-3/4" HEX HEAD BOLT	2
3/4"-16 HEX HEAD NUT	4
3/4"-16 FRAME NUT	2
3/4" INTERNAL TOOTH LOCKWASHER	2
3/4" LOCK WASHER	2
3/4" FLAT WASHER	8
3/4" THICK FLAT WASHER	2
INFLATION VALVE	2
1/4 NPT STRAIGHT FITTING	2

Figure "A"

Find the closest point between the exhaust pipe and the air spring. Mount the heat shield in this location.

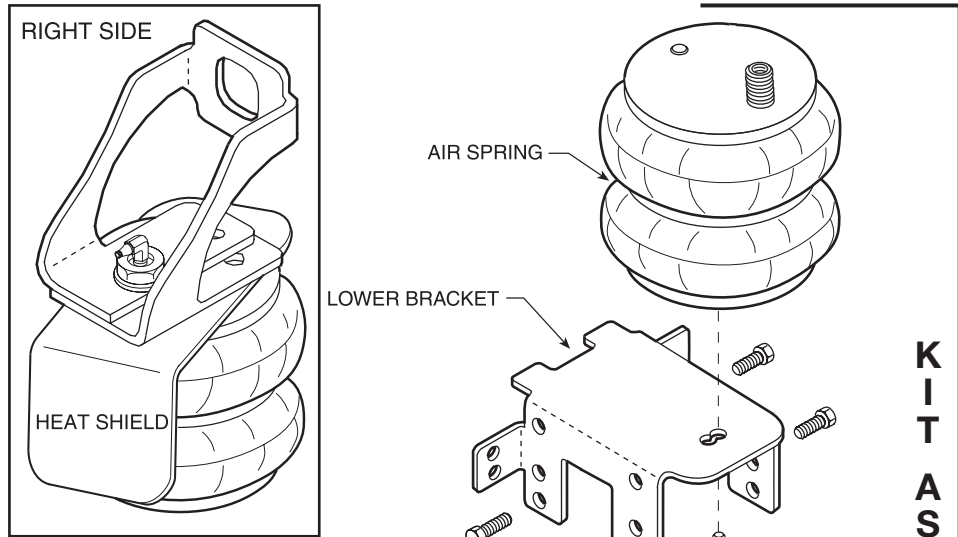

**NOTE:** This diagram is of the left side of the truck. Reverse any orientations when assembling and installing the right side of the vehicle.

**KIT TO FRAME ASSEMBLY**

⚠ See Figure "B" for Upper Bracket mounting. ⚠

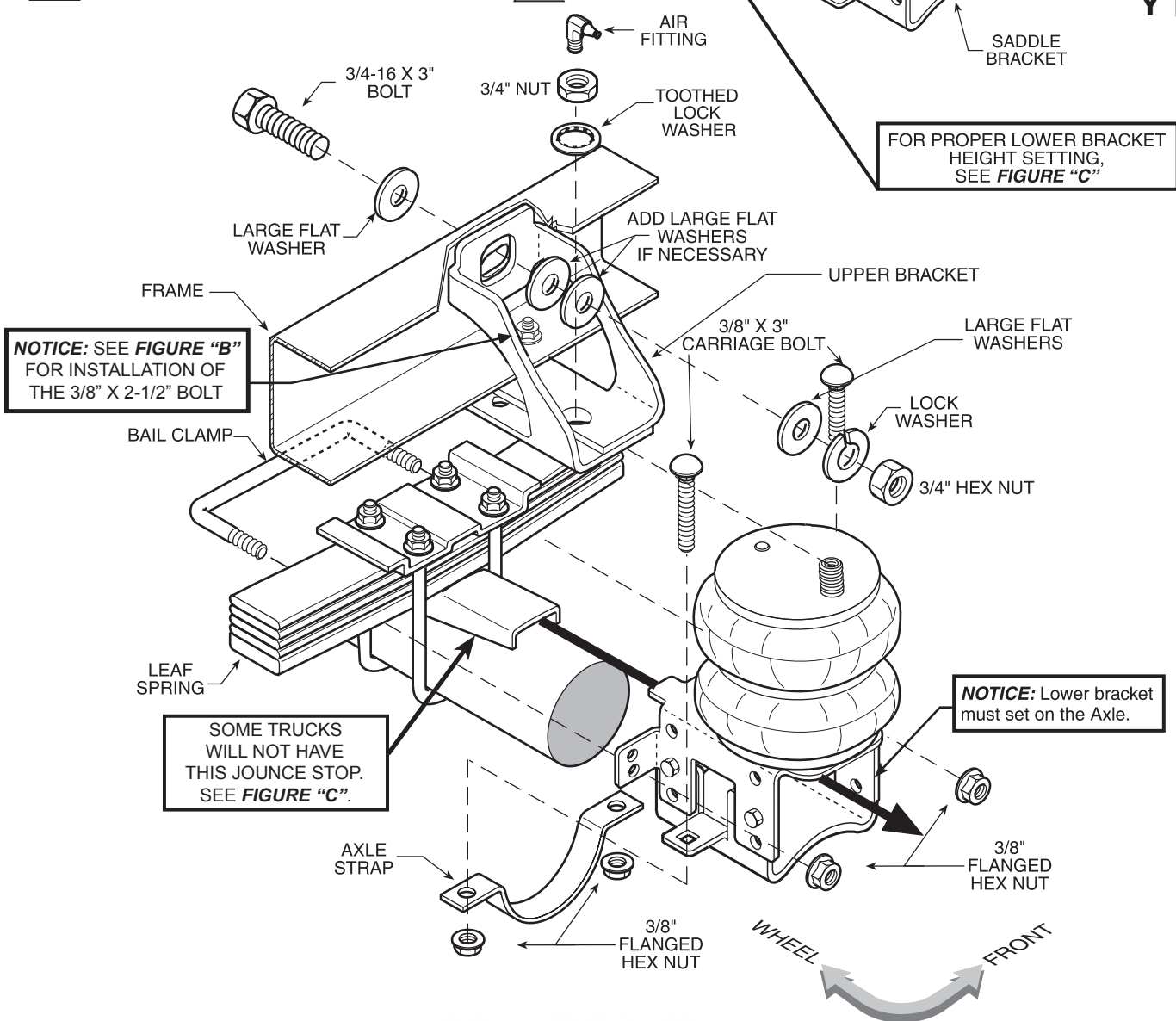
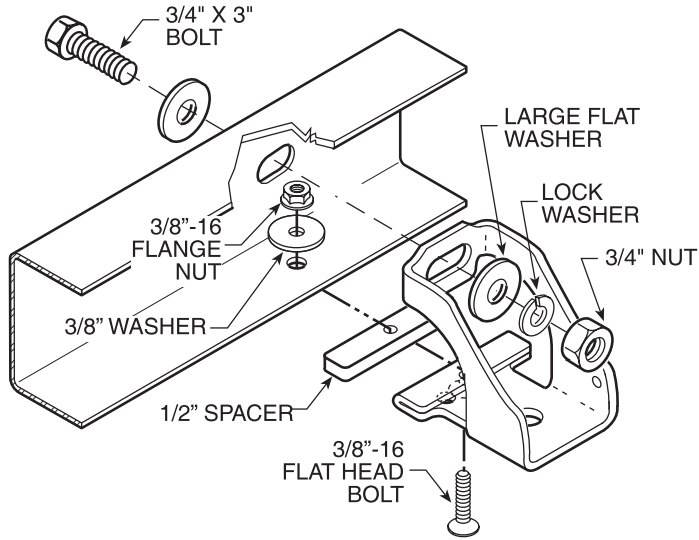
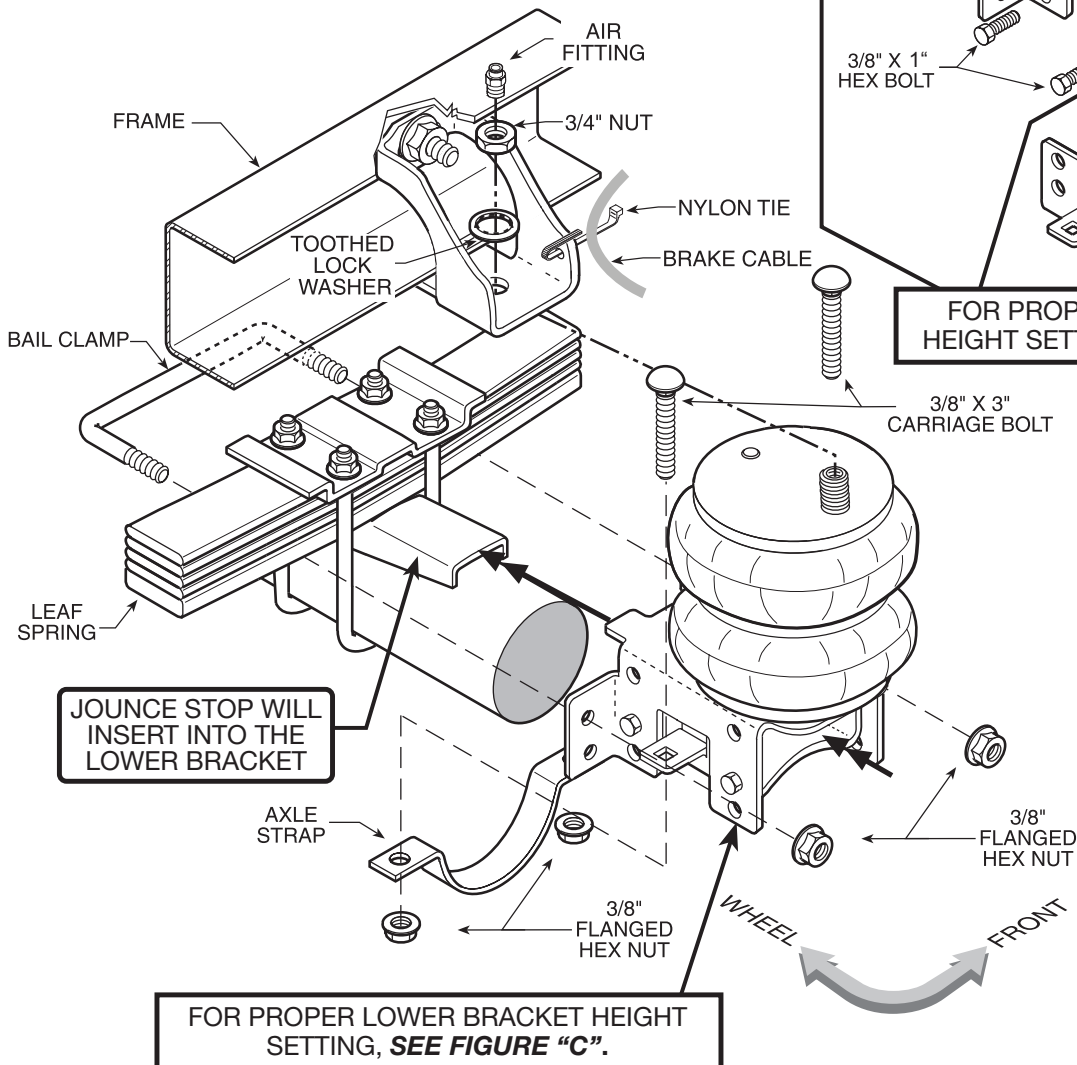

Figure "A"



**UPPER BRACKET ATTACHMENT**

**KIT TO FRAME ASSEMBLY**



**Note:** This diagram is of the left side of the truck. Reverse any orientations when assembling and installing the right side of the vehicle.

**KIT ASSEMBLY**

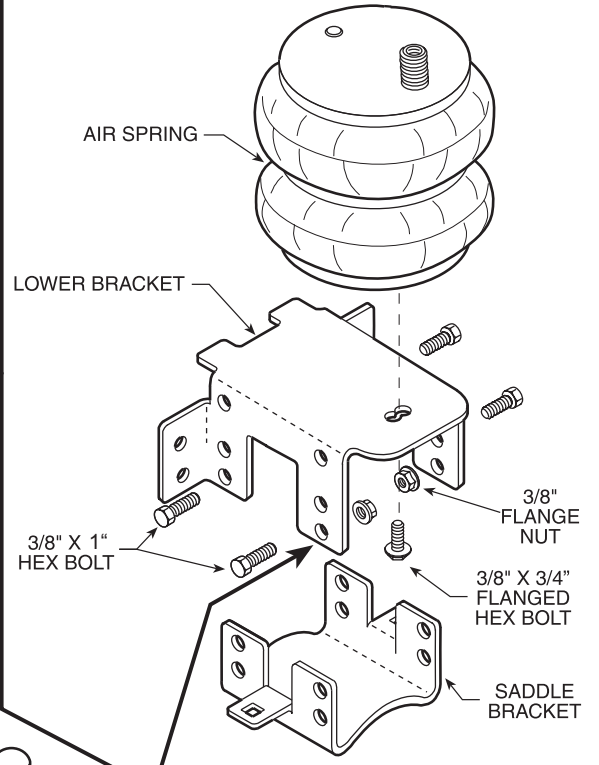

FOR PROPER LOWER BRACKET HEIGHT SETTING, SEE FIGURE "C".

Figure "A"

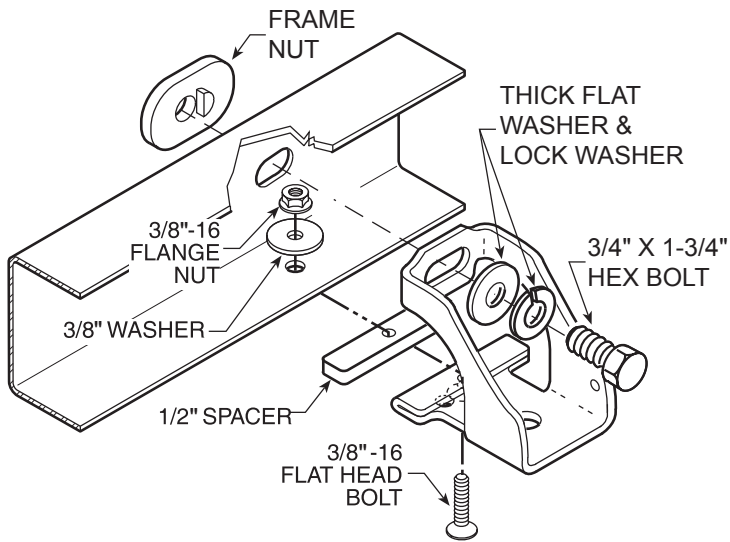

**UPPER BRACKET ATTACHMENT**

**KIT TO FRAME ASSEMBLY**

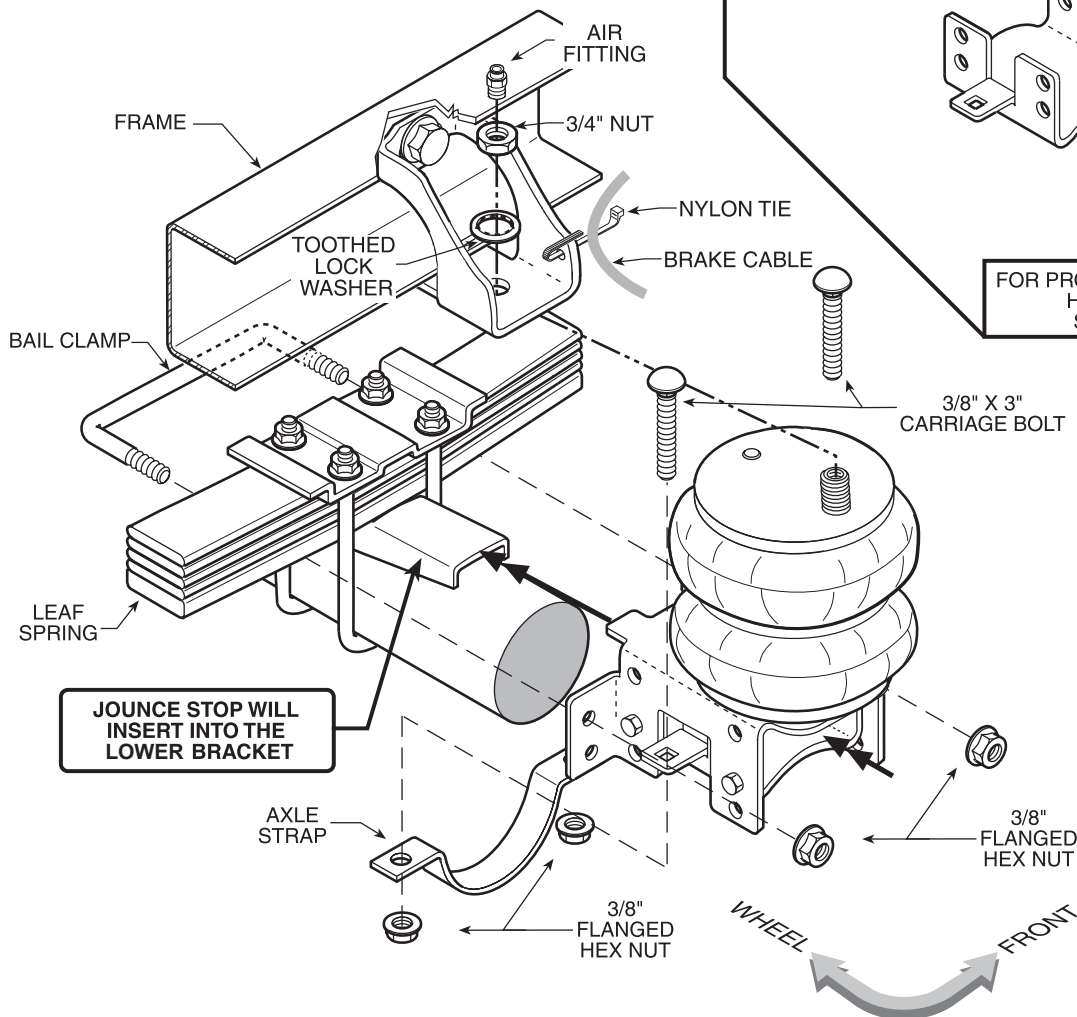

JOUNCE STOP WILL INSERT INTO THE LOWER BRACKET

**Note:** This diagram is of the left side of the truck. Reverse any orientations when assembling and installing the right side of the vehicle.

**K I T A S S E M B L Y**

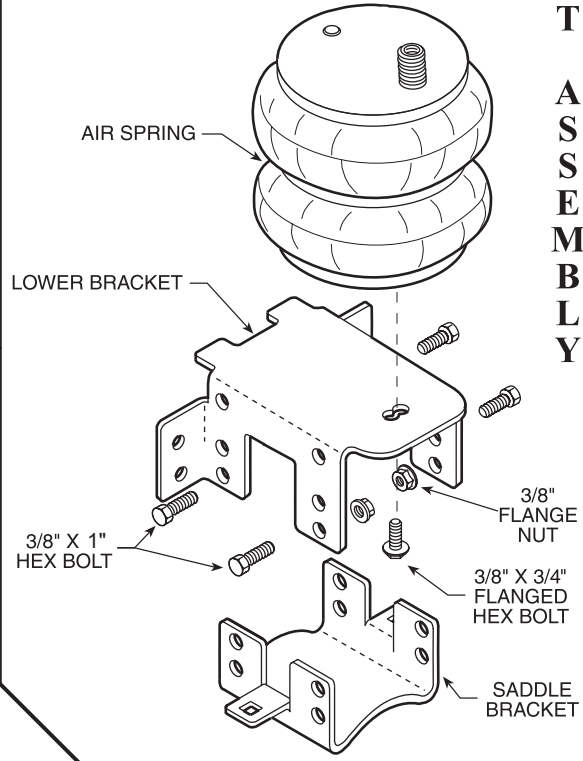

FOR PROPER LOWER BRACKET HEIGHT SETTING, SEE FIGURE "C"

## STEP 1—PREPARE THE VEHICLE

Place the truck on a solid level surface. Remove the negative battery cable. Take necessary safety precautions such as using wheel chocks when working on your truck.

On some 2008 and newer trucks some lines must be repositioned on the left side of the vehicle. Remove the nut holding the fuel line retaining clip. Rotate the retaining clip 90 degrees with the stud facing down. Install the relocation bracket with the nut previously removed. Next fasten the retaining clip to the relocation bracket using a 5/16"-24 x 3/4" bolt and 5/16"-24 flange nut.

Your truck is equipped with jounce bumpers attached to the frame directly above the axle. Remove these bumpers by unbolting from the inside of the frame flange. These bumpers will not be re-used with this kit. For vehicles from 1999 to 2004 please save the collar as it will be re-used in Step 2B.

## STEP 2A—UPPER BRACKET INSTALLATION FOR 2008 AND UP TRUCKS

Insert the 3/8"-16 x 2-1/2" flat head bolt into the upper bracket and then slide the spacer over the bolt. Install the upper bracket onto the frame. Make sure that no part of the vehicle's wiring will be pinched between the upper bracket and the frame. Tighten the 3/8"-16 flat head bolt with a 3/8" large flat washer and 3/8"-16 flange nut. The emergency brake cable will have to be tie-wrapped out of the way using the hole provided in the upper bracket. **See Figure "A"**.

On trucks without factory installed in-bed hitch, install the 3/4"-16 x 3" hex bolt through the existing hole in the frame rail and upper bracket. Secure the 3/4"-16 x 3" bolt with a 3/4" flat washer, 3/4" lock washer and a 3/4"-16 hex nut.

On truck with a factory installed in-bed hitch, install the 3/4"-16 x 1-3/4" hex bolt through the existing hole in the frame rail and upper bracket. Secure the 3/4"-16 x 1-3/4" bolt with a 3/4" thick flat washer, 3/4" lock washer and a 3/4"-16 flange nut.

## STEP 2B—UPPER BRACKET INSTALLATION FOR 1999 TO 2004 TRUCKS

Make sure that no part of the vehicle's wiring will be pinched between the upper bracket and the frame. At this time, the collar that was on the jounce bumper will be reused. Insert the collar into the original hole on the frame. Put the upper bracket in place (to hold the collar) while you insert the 3/8"-16 x 2-1/2" flat head bolt into the upper bracket and collar. **See Figure "B"**. Secure the 3/8"-16 flat head bolt with a 3/8" large flat washer and 3/8"-16 flange nut finger tight.

Hold the upper bracket tight against the bottom of the frame. If the bracket appears to be level with the upper part of the bracket rests against the inside of the frame, install the 3/4"-16 x 3" bolt through the frame rail and upper bracket. If the top of the bracket does not set level, install some of the large 3/4" flat washers between the bracket and the inside of the frame rail. If you have existing hitch hardware, the 3/4" bolt should be long enough to extend through the upper bracket, truck frame and hitch brackets. Be sure to install at least one of the large flat washers and the 3/4" lock washer before installing the 3/4"-16 hex nut onto the bolt. After you have installed the upper bracket as level as possible, tighten the 3/8"-16 x 2 1/2" flat head bolt in the bottom of the frame, then tighten the 3/4"-16 x 3" bolt through the side of the frame. The emergency brake cable will have to be tie-wrapped out of the way using the hole provided in the upper bracket. **See Figure "A"**.

## STEP 3—AIR SPRING INSTALLATION

The heat shield will be used on the exhaust side of the truck only. It is placed between the upper bracket and the top of the air spring. **See Figure "B"**. The alignment pin on top of the

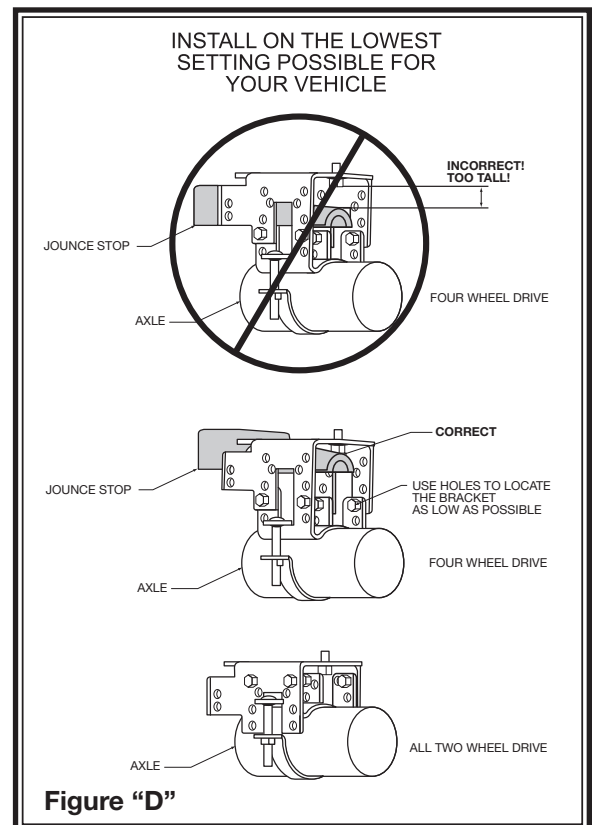
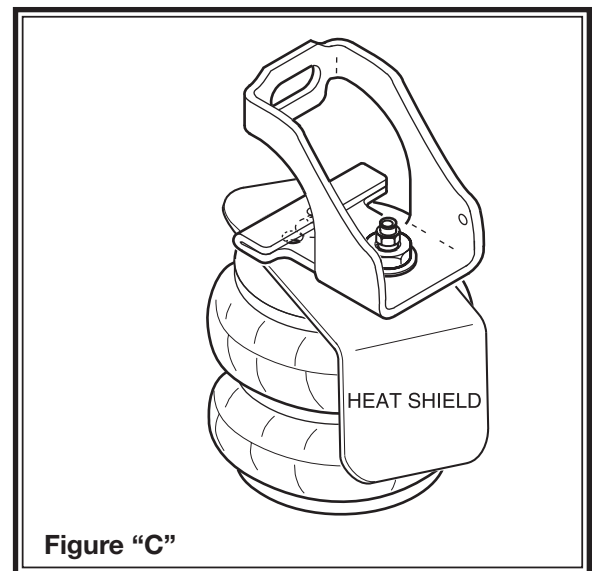
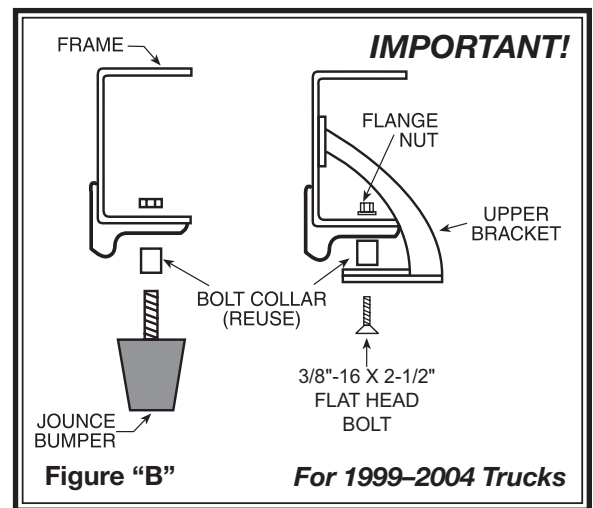

air spring **must** be aligned with the hole in the upper bracket towards the front of the truck, on both sides. When the air spring is in place and properly aligned, install the internal tooth lock washer and  $\frac{3}{4}$ "-16 hex nut onto the stud of the air spring. On the right side, align the heat shield before tightening the  $\frac{3}{4}$ "-16 hex nut on the air spring. Make sure the heat shield will not interfere with the normal operation of the air spring or the vehicle's suspension. Do not position the face of the directly over the axle, as it may contact the axle on full suspension compression. Next install the air fitting into the stud of the air spring. Tighten the air fitting securely to engage the orange thread sealant.

#### STEP 4—LOWER BRACKET INSTALLATION

Four wheel drive trucks will have a cast iron jounce stop as shown in **Figures "A" and "C"**. If this jounce stop is present, the height setting of the lower bracket assembly needs to be just above the jounce stop (to clear the head of the bolt in the bottom of the air spring). On two wheel drive trucks assemble the lower assembly to the shortest setting. **See Figure "C"**.

**The lower bracket assembly should be installed on the lowest setting possible for the truck. See Figure "C"**.

The saddle and lower bracket are bolted together using four  $\frac{3}{8}$ "-16 x 1" bolts and flange nuts to make up the lower bracket assembly. When the assembly is bolted together at the proper height, install the  $\frac{3}{8}$ "-16 x  $\frac{3}{4}$ " flange blot through the forward hole on the lower bracket into the bottom of the air spring and tighten.

Place the lower bracket assembly against the leaf spring stack making sure that the top of the lower bracket fits in between the axle U-bolts. Place the bail clamp around the axle block and install the  $\frac{3}{8}$ "-16 flange nuts onto the bail clamp and tighten.

Insert the carriage bolts through the square holes on the lower bracket assembly being careful not to chaff or pinch the brake lines on the axle. Next push the axle strap onto the bottom of the axle and through the carriage bolts. When the  $\frac{3}{8}$ "-16 flange nuts are tightened, they will draw the axle strap into place.

#### STEP 5—AIR TUBING INSTALLATION

Uncoil the air tubing and cut into two equal lengths. **DO NOT FOLD OR KINK THE TUBING.** Try to make the cut as square as possible. Insert one end of the tubing into the straight fitting installed in the top of the air spring. Push the tubing into the fitting as far as possible. Select a location on the vehicle for the air inflation valves. This can be on the bumper or the body of the truck, as long as it is protected so the valves will not be damaged. Drill a  $\frac{5}{16}$ " hole and install the air inflation valve using two  $\frac{5}{16}$ " flat washers per valve as supports. Route the air tubing from the air spring to the inflation valve, avoiding direct heat from the engine and exhaust pipe while keeping it away from sharp edges as well. The air tubing should not be bent or curved sharply as in may kink with time. Secure the tubing in place with the tie-wraps provided. Push the end of the air tubing into the inflation valve as far as possible. **See Figures "E" and "F"**.

#### STEP 6—CHECK THE SYSTEM

Visually check for loose attaching bolts. Make sure that no part of the truck is rubbing against the air springs. Again, make sure that the truck's brake lines are not pinched or being rubbed by any part of your air spring kit.

Inflate the air springs to 50 psi and check the fittings for air leaks with an applied solution of soap and water. If a leak is detected, deflate the air spring by depressing the valve core. The tubing can easily be removed from the fittings by pushing the collar towards the body of the fitting while pulling out the tube. Next check the tubing connection to ensure that the air tubing is cut as square as possible and that it is pushed completely into the fitting.

If a leak is detected where the air fitting screws into the air spring, gently tighten the air fitting into the spring until the leak stops. Also check the core of the inflation valve. The valve core can be tightened using the valve cap provided. Re-inflate the air springs and check for leaks again if needed. This now completes the installation. Reconnect the battery cable and remove the wheel chocks.

**NOTE: THE OPERATION PRESSURE OF THIS KIT IS 5 PSI MIN. TO 100 PSI MAX.**

**Too much air pressure in the air springs will result in a firmer ride, while too little air pressure will allow the air springs to bottom out over rough conditions. Too little air pressure will also not provide the improvement in handling that is possible. TO PREVENT POSSIBLE DAMAGE MAINTAIN A MINIMUM OF 5 psi IN THE AIR SPRINGS AT ALL TIMES.**

Once the air springs are installed, it is recommended that the vehicle not be lifted by the frame, as over-extension may occur, resulting in damage to the air springs. However, should it become necessary to raise the vehicle by the frame, deflate both air springs completely.

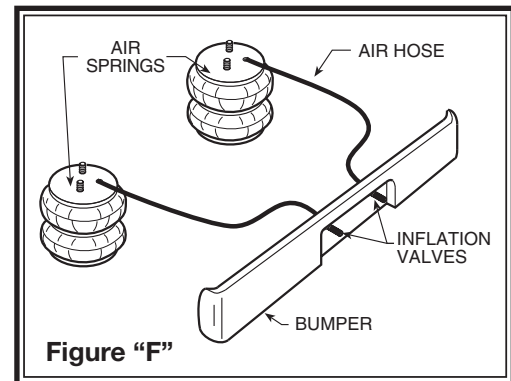
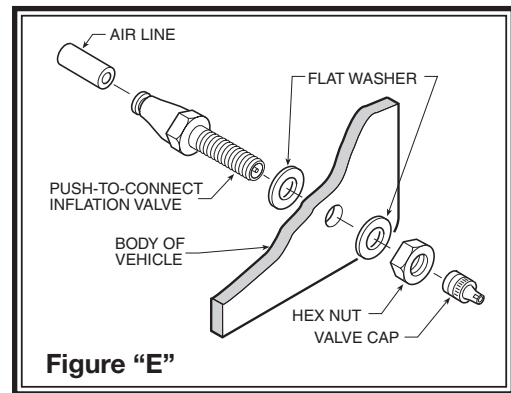

# **COMBO STUD NOTICE:**

THE ALIGNMENT PIN ON THE AIR SPRING **MUST** BE INSTALLED INTO THE HOLE IN THE UPPER BRACKET.

FAILURE TO DO SO WILL CAUSE THE ALIGNMENT PIN TO BE PUSHED INTO THE BEAD PLATE, CREATING AN AIR LEAK, AND RESULTING IN AN AIR SPRING FAILURE THAT IS **NOT WARRANTABLE.**

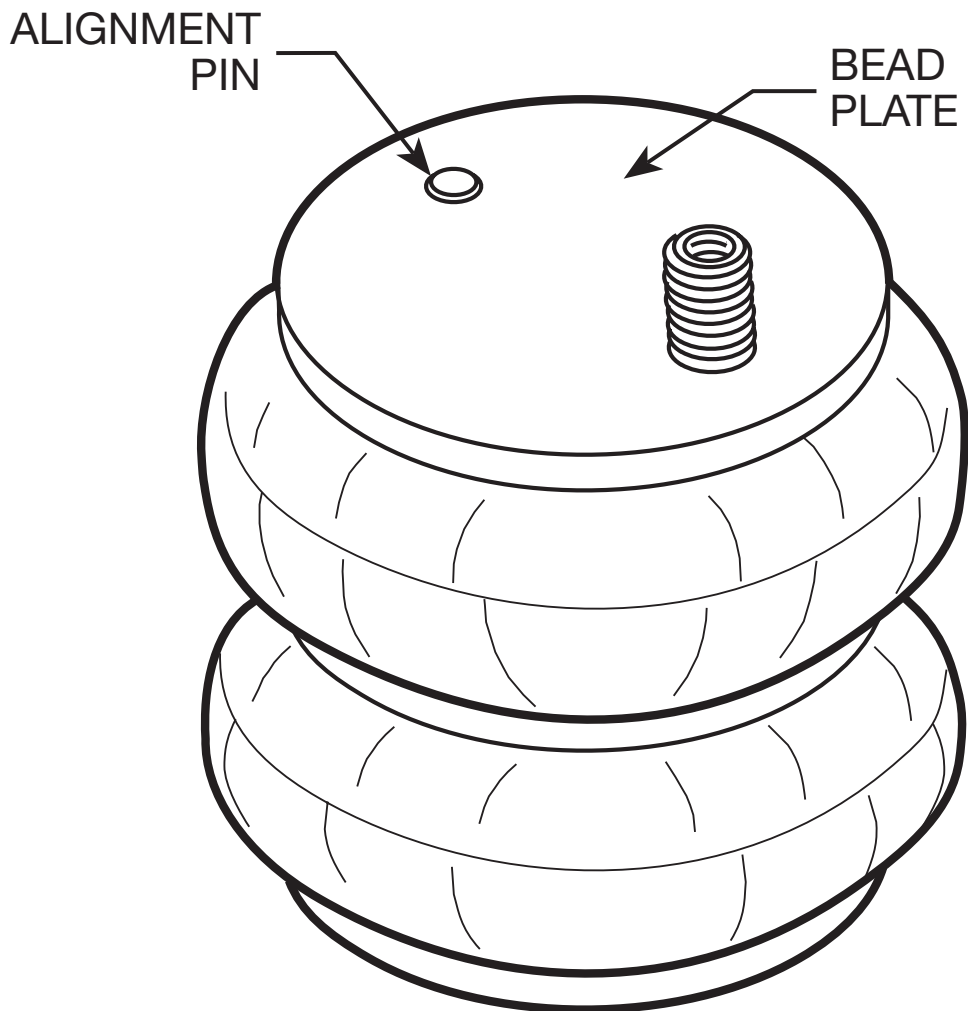

**RIDE-RITE**  
**SPORT-RITE COIL-RITE**  
AIR HELPER SPRINGS

[www.riderite.com](http://www.riderite.com)  
**TruckSpring.com**  
SUSPENSION SPECIALISTS+