**WARNING:**

Do not inflate this assembly when it is unrestricted. The assembly must be restricted by the suspension or other adequate structure. Do not inflate beyond 100 psi. Improper use or overinflation may cause property damage or severe personal injury.

INSTALLATION INSTRUCTIONS

Congratulations - your new air helper springs are quality products capable of improving the handling and comfort of your vehicle. As with all products, proper installation is the key to obtaining all of the benefits your kit is capable of delivering. Please take a few minutes to read through the instructions to identify the components and learn where and how they are used. It is a good idea to start by comparing the parts in your kit with the parts list below.

The heart of the air spring kit is, of course, the air helper springs. Remember that the air springs must flex and expand during operation, so be sure that there is enough clearance to do so without rubbing against any other part of the vehicle.

Be sure to take all applicable safety precautions during the installation of the kit. The instructions listed in this brochure and the illustrations all show the right, or passenger's side of the vehicle. To install the left side assembly, simply follow the same procedures.

Your kit includes separate inflation valves and air line for each air helper spring. This will allow you to level your vehicle from side to side as well as from front to back. If you would rather have a single valve inflation system, your dealer can supply the required T-fitting.

IMPORTANT!

For your safety and to prevent possible damage to your vehicle, do not exceed the maximum load recommended by the vehicle manufacturer (GVWR). Although your Air Helper Springs are rated at a maximum inflation pressure of 100 psi, this pressure may allow you to carry too great a load on some vehicles. It is best to have your vehicle weighed once it is completely loaded and compare that weight to the maximum allowed. Check your vehicle owner's manual or data plate on driver side door for maximum loads listed for your vehicle.

When inflating your Air Helper Springs, add air pressure in small quantities, checking pressure frequently during inflation. The air spring requires much less air volume than a tire and, therefore, inflates much quicker.

PARTS LIST

AIR SPRING	7076	2	3/8" FLAT WASHER	4
UPPER BRACKET	5219	2	3/4" -16 NYLON-INSERT HEX NUT	2
LOWER BRACKET	5098	2	3/4" WASHER	2
DISK	5204	2	5/16" FLAT WASHER	4
BRACKET STRAP	5086	2	PUSH-TO-CONNECT	
3/8" -16 x 1-1/2" HEX BOLT		8	INFLATION VALVE	3098 2
3/8" -16 FLANGED LOCK NUT		12	ELBOW FITTING	3128 2
3/8" -16 x 3/4" FLANGED HEX BOLT		2	AIR LINE TUBING	1
3/8" -16 x 3-1/2" CARRIAGE BOLT		4	THERMAL SLEEVE	2
3/8" LARGE FLAT WASHER		4	NYLON TIE	6

NOTE: Both illustrations are of the right, or passenger's side of the vehicle. Reverse any orientations when assembling and installing the left, or driver's side of the vehicle.

KIT ASSEMBLY

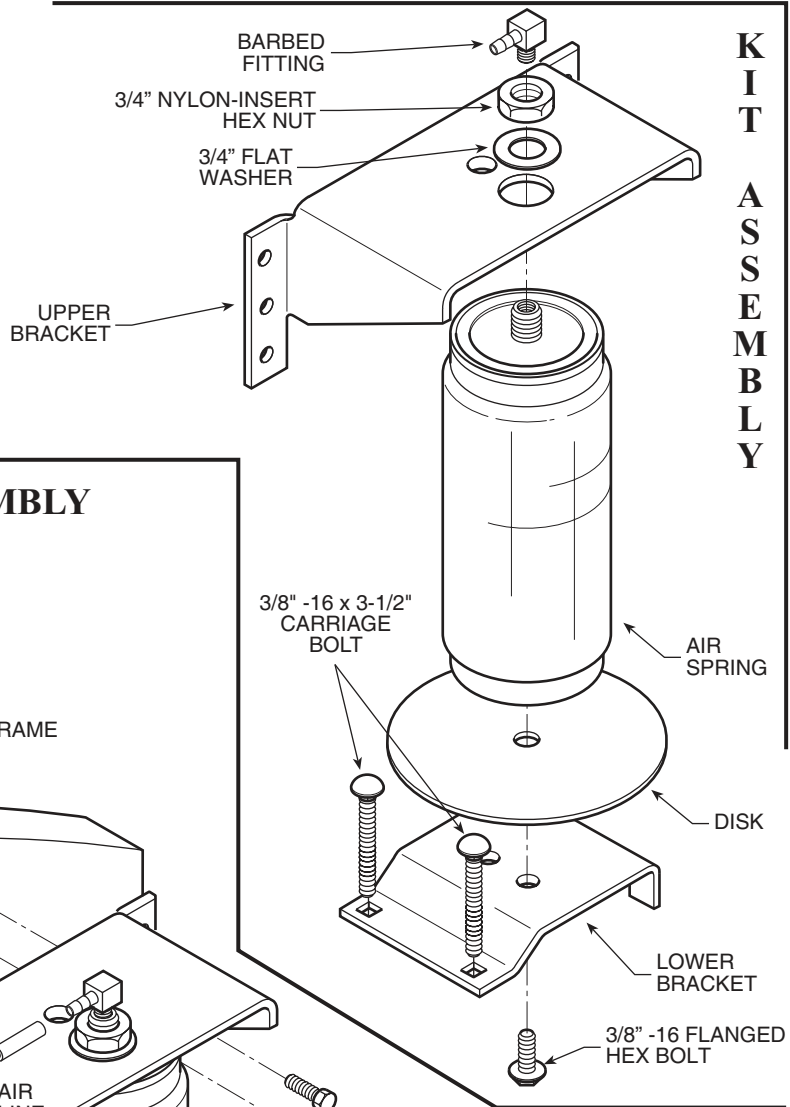

KIT TO FRAME ASSEMBLY

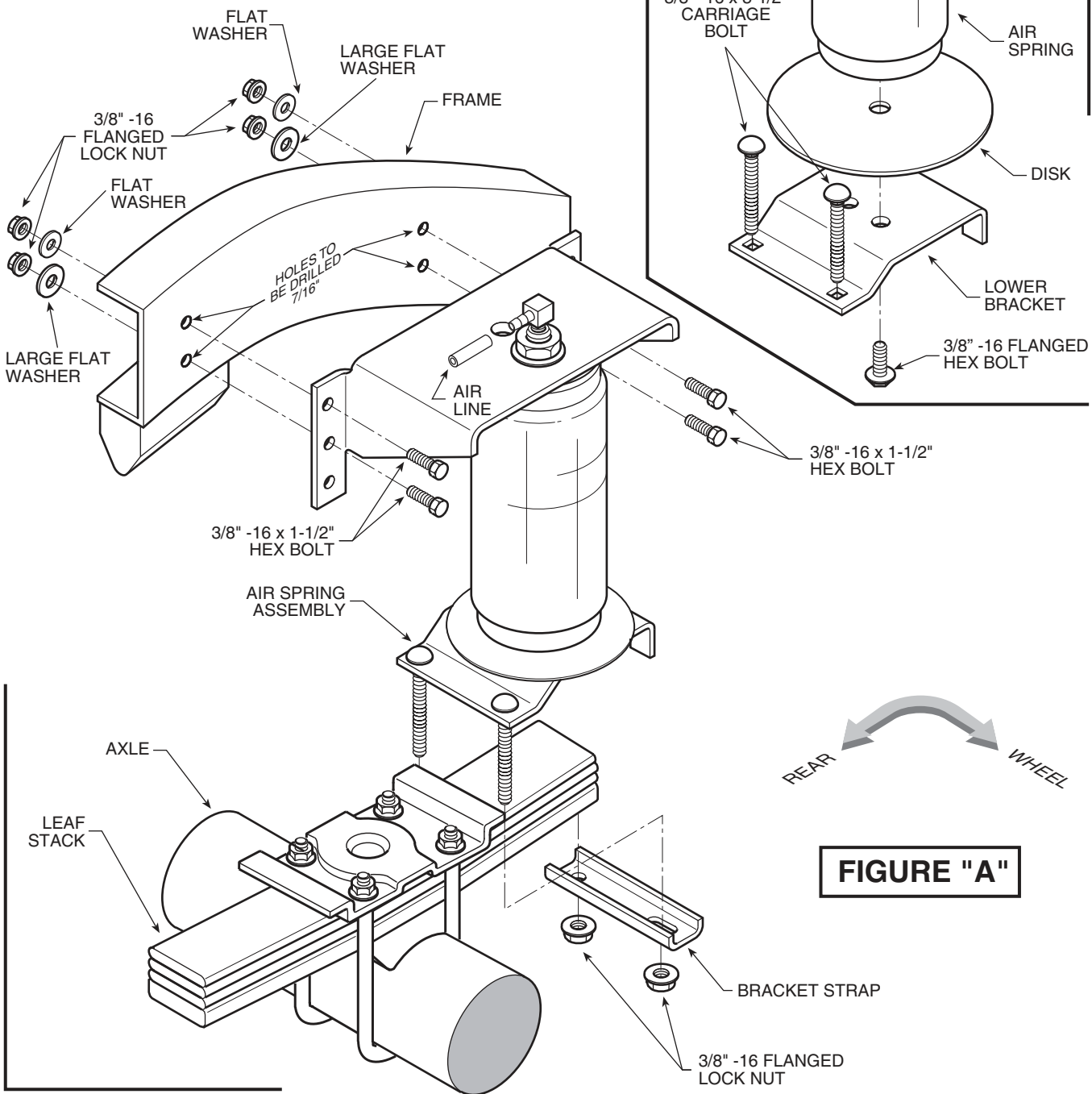

FIGURE "A"

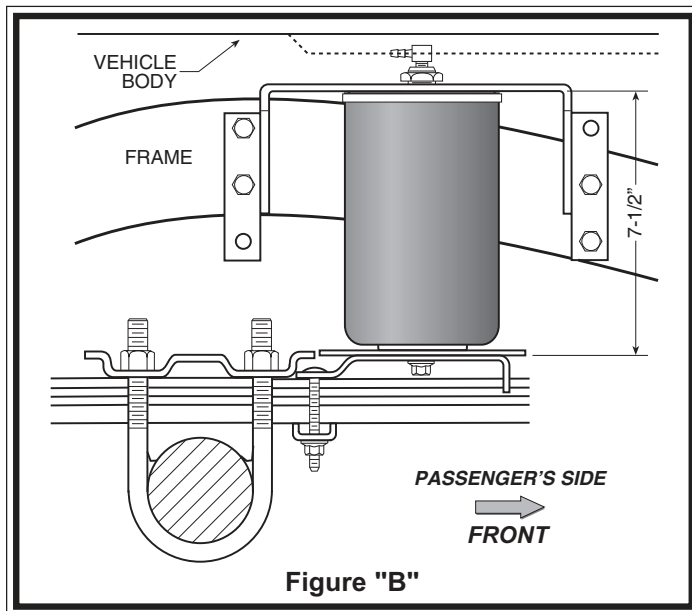

Figure "B"

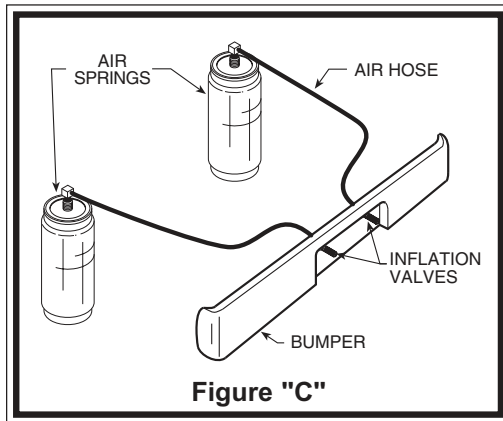

Figure "C"

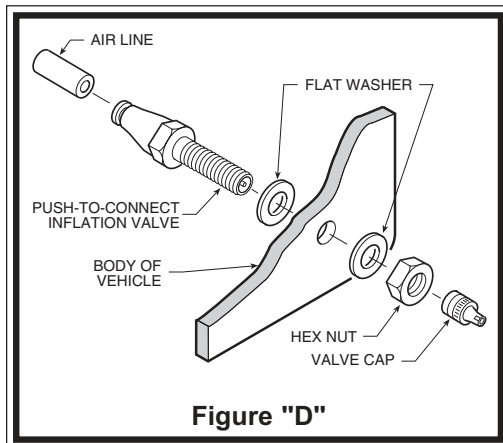

Figure "D"

STEP 1 - PREPARE THE VEHICLE

With the vehicle on a solid level surface, chock the front wheels. Raise the vehicle by the axle and remove the rear wheels. After the removal of the wheels, lower the vehicle so the axle rests on jack stands rated for your vehicle's weight. Remove the negative battery cable.

STEP 2 - PREASSEMBLE THE KIT

Preassembly will begin with the right, or passenger's side of the vehicle. All instructions and illustrations show the right-side assembly unless otherwise noted.

Select one air helper spring from your kit. Install the upper bracket by aligning the threaded stud on the air spring with the large hole on the upper bracket. Fasten the upper bracket to the air spring using the supplied 3/4" nylon-insert hex nut and 3/4" washer *see Figure "A"*. Install the barbed air fitting into the top of

the air spring. Tighten the air fitting sufficiently to engage *at least* two threads with the pre-applied thread sealant. Orient the fitting so that it points toward the anticipated location of the inflation valve.

Insert the two 3/8" -16 x 3" carriage bolts into the square holes in the lower bracket. Insert a 3/8" -16 x 3/4" flanged hex bolt through the bottom of the lower bracket, through the disk, and thread the hex bolt into the bottom of the air spring *see Figure "A" (finger tight)*.

STEP 3 - ATTACH THE LOWER BRACKET TO THE LEAF SPRING

Place the assembly on top of the leaf spring stack forward of the axle *see Figures "A" & "B"*. The lower bracket should be butted against the leaf spring retainer on top of the leaf spring *see Figure "B"*. Attach the lower bracket to the leaf stack by installing a bracket strap over the 3/8"-16 x 3" carriage bolts installed earlier *see Figures "A" & "B"*. Secure the bracket strap by installing two 3/8" -16 flanged hex nuts on the 3/8" -16 x 3" carriage bolts.

STEP 4 - MARK AND DRILL THE HOLES IN THE FRAME RAIL

Align the air spring so that it is as close to vertical as possible and the upper and lower brackets are parallel. Position the upper bracket so that the distance between the upper and lower brackets is approximately 7-1/2" *see Figure "B"*. There should be 1/4" to 1/2" of clearance between the fitting on the top of the air spring and the bottom of the vehicle's body. Note that the two lower holes will be used to attach the forward flange to the frame rail while the rear flange will use the upper mounting holes *see Figure "B"*. Using the mounting holes in

the upper bracket as a template, mark the location of the holes to be drilled in the frame rail with a center punch. Drill four 7/16" holes on the center marks, making sure that any brake, fuel, or electrical lines inside the frame rail will not be damaged by the drill *see Figure "B"*.

STEP 5 - ATTACH THE UPPER BRACKET

Once the holes have been drilled in the frame rail, attach the upper bracket using the supplied 3/8" -16 x 1-1/2" hex bolts, large flat washers, and the 3/8" -16 flanged hex nuts *see Figure "A"*. Tighten the 3/8" -16 x 3/4" flanged hex bolt securing the air spring to the lower bracket.

STEP 6 - INSTALL THE DRIVER'S SIDE ASSEMBLY

Follow steps 1-5 for assembly and installation of the driver's side assembly. Reverse any orientations for the driver's side installation.

STEP 7 - INSTALL THE AIR LINE AND INFLATION VALVES

Uncoil the air tubing and cut it into two equal lengths. *DO NOT FOLD OR KINK THE TUBING*. Try to make the cut as square as possible. Slide the tubing as far as possible onto the barbed fitting on the top of the air spring *see Figures "A" & "C"*. Before attaching the air line tubing to the barbed fitting, soak the end of the tube (1") in hot water for a few minutes to soften the tubing. Do not use pliers to work the tubing on to the fitting, as the tubing may be damaged.

Select a location on the vehicle for the air inflation valves. The location can be on the bumper or the body of the vehicle, as long as it is in a protected location so the valves will not be damaged, but maintain accessibility for the air chuck *see Figure "C"*. Drill two 5/16" holes and install the air inflation valves using two 5/16" flat washers per valve as supports *see Figure "D"*. Route the tubing from the air helper springs to the inflation valves, routing it to avoid direct heat from the exhaust pipe and away from sharp edges. Thermal sleeves have been provided for these conditions. If a thermal sleeve is needed, simply slide the sleeve over the tubing to the location requiring protection. The air line should not be bent or curved sharply, as it may buckle. Secure the tubing to the vehicle using the supplied nylon ties. Push the end of the air line tubing into the inflation valve as far as possible *see Figure "D"*.

STEP 8 - CHECK THE SYSTEM

Once the inflation valves are installed, inflate the air helper springs to 50 *psi* and check the fittings for air leaks with an applied solution of soap and water. If a leak is detected at the inflation valve, check to make sure that the tube is cut as square as possible and that it is pushed completely into the fitting. If a leak is detected at the barbed fitting, check to make sure that the tubing is pushed onto the barb as far as possible. The tubing can easily be removed from the inflation valves. First, release the air pressure from the air springs. Push the collar toward the body of the fitting and pull out the tube. Reinstall the tubing and reinflate the air springs and check for leaks as noted above.

This now completes the installation. Install the wheels and torque the lug nuts to the manufacturer's specifications. Raise the vehicle by the rear axle and remove the jack stands. Lower the vehicle back onto the ground. Reattach the negative battery cable and remove the wheel chocks from the front wheels. Before proceeding, check once again to be sure you have proper clearance around the air springs. With a load on your vehicle and the air helper springs inflated, you must have at least 1/2" clearance around the air springs. As a general rule, the air helper springs will support approximately 10 lbs of load for each *psi* of inflation pressure (per pair). For example, 50 *psi* of inflation pressure will support a load of approximately 1000 lbs per pair of air helper springs. *FOR BEST RIDE*, use only enough air pressure in the air helper springs to level the vehicle when viewed from the side (front to rear). This amount will vary depending on the load, location of the load, condition of existing suspension, and personal preference.

NOTE:

Too much air pressure in the air helper springs will result in a firmer ride, while too little air pressure will allow the air helper spring to bottom out over rough conditions. Too little air pressure will also not provide the improvement in handling that is possible. *TO PREVENT POSSIBLE DAMAGE MAINTAIN A MINIMUM OF 10 PSI IN THE AIR HELPER SPRINGS AT ALL TIMES.*

NOTE:

Once the air helper springs are installed, it is recommended that the vehicle not be lifted by the frame, as over-extension may occur, resulting in damage to the air helper springs. However, should it become necessary to raise the vehicle by the frame, deflate both air helper springs completely.