



DIGITAL AIR COMMAND

INSTALLATION INSTRUCTIONS

Congratulations on your purchase of a Digital Air Command kit. This kit was designed to provide inflation control of your air helper springs. This kit will be an asset to your vehicle, meeting nearly all of your air supply needs.

Please take a few minutes to read through the instructions to identify the components and learn how to properly install your Digital Air Command kit.

NOTE:

The Digital Air Command kit can be used with all air helper spring products. If you are installing an air suspension system, do not install the air line tubing to the air springs as stated in the suspension system instruction manual. If you are adding the Digital Air Command kit to an existing air suspension system, you will need to deflate ht air springs and remove the air line tubing.

NOTE ON CONNECTING THE AIR LINE TUBING

Cut the air line tubing as squarely as possible. To connect the air line tubing to the fittings, push the tubing into the fittings as far as possible. If for any reason the tubing must be removed, first release the air pressure from the air helper spring. Push the collar towards the body of the fitting and then pull out the tubing. To reassemble, make sure the tubing is cut squarely and push the tubing back into the fitting.

TOOLS NEEDED:

Center Punch	3/16" Drill Bit
3/8" Drill	Wire Crimpers
3/8" Wrench	1/2" Wrench
5/8" Wrench	7mm Wrench
Phillips Screwdriver	

PARTS LIST

DIGITAL GAUGE	9325	1	10-32 X 3/4" MACHINE SCREW	2
AIR COMPRESSOR	9283	1	10-32 X 1" MACHINE SCREW	4
VALVE BLOCK	9318	1	10-32 X 1 1/2" MACHINE SCREW	2
PRESSURE SENSOR	9054	1	10-32 NYLOCK NUT	8
EXHAUST VALVE	9278	1	SMALL RING TERMINAL	2
WIRE HARNESS	9320	1	MEDIUM RING TERMINAL	1
30 FT. AIR LINE	9008	1	18 GA. X 2' BLACK WIRE	1
MALE FITTING	3025	4	FOAM TAPE	2
3/16" FLAT WASHER		9	NYLONTIE	15

FIGURE "A"

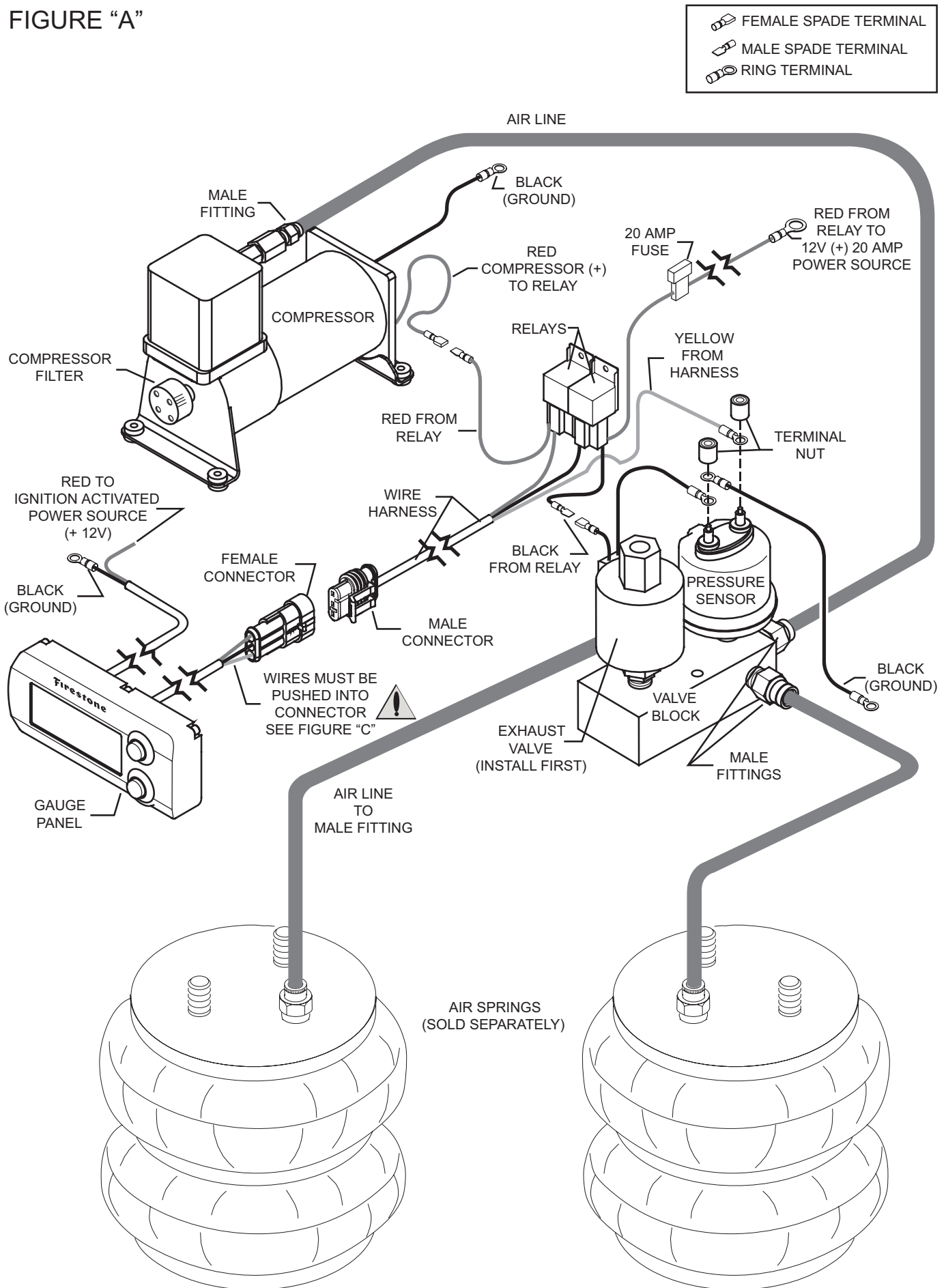

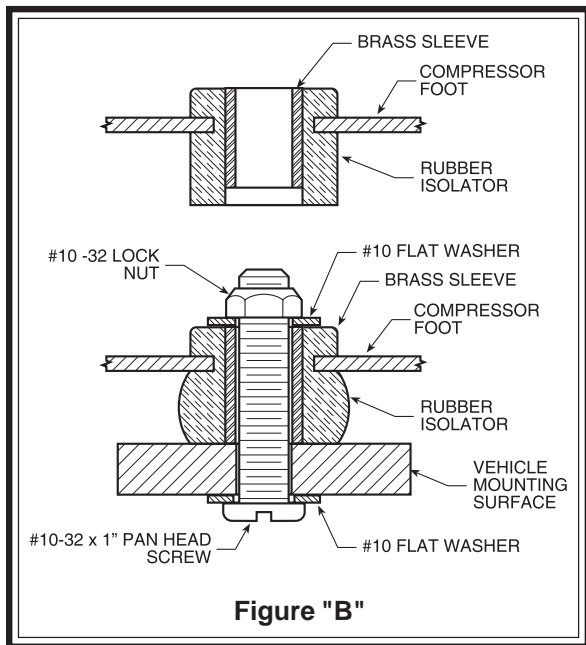

STEP 1 – MOUNT THE COMPRESSOR

Begin by removing the negative battery cable. Select a convenient location to mount the compressor. This location should provide ample air flow and be protected from airborne debris and moisture. The mounting surface should be rigid to support the compressor. The compressor is oil-less and can be mounted in any orientation necessary for installation. Make sure that the wire harness will reach from the compressor to the anticipated location of the digital gauge. Install a male fitting into the threaded output port on the compressor head, *see Figure "A"*. Tighten the fitting sufficiently to engage at least two threads with the pre-applied thread sealant. **DONOT OVER TIGHTEN THE FITTING.** Mark the four compressor mounting holes using the compressor as a template and a center punch, then drill four 3/16" holes. Mount the compressor using the supplied 10-32 x 1" machine screw, 10-32 nylock nuts and 3/16" washers. *See Figure "B"*. Attach the black wire from the compressor to a convenient ground source on the vehicle.

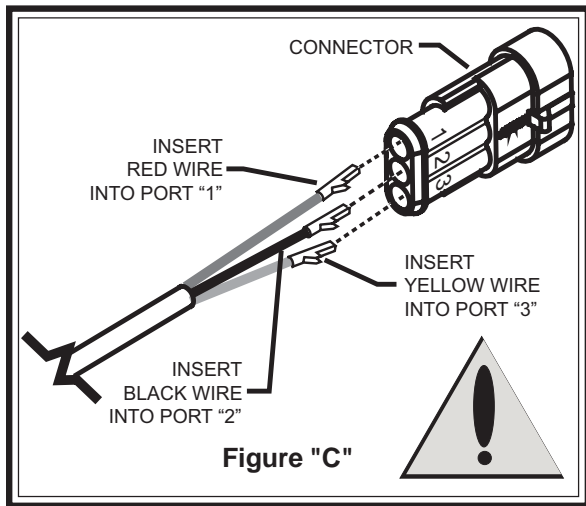

STEP 2 – MOUNT THE MANIFOLD BLOCK

Select the valve block from your kit and install the exhaust valve into the top of the manifold block. Tighten the valve sufficiently to engage at least two threads with the pre-applied thread sealant. Install the pressure sensor into the top of the valve block next to the exhaust valve. Install the three male fittings into the side of the valve block. Tighten the fittings sufficiently to engage at least two threads with the pre-applied thread sealant. *See Figure "A"*. Select a convenient location to mount the valve block next to the compressor. Mark the two mounting holes using the valve block as a template and a center punch, then drill two 3/16" holes. Mount the valve block using the supplied 10-32 x 1-1/2" machine screws and 10-32 nylock nuts.

STEP 3 – GROUNDING THE COMPONENTS ON THE MANIFOLD BLOCK

Take one wire from the exhaust valve and cut the female spade terminal off, then strip and crimp a small ring terminal on the end of the wire. Next, take the black wire from your kit and strip both ends. On one end, crimp a small ring terminal and on the other end, crimp the medium ring terminal. Install the small ring terminal from the black ground wire and the black wire with the ring terminal from the exhaust valve onto one of the threaded terminals on the pressure sensor. Tighten the nut on the pressure sensor terminal figure tight. **DONOT OVERTIGHTEN THE TERMINAL NUT.** Connect the other end of the ground wire to a suitable ground source on the vehicle. *See Figure "A"*.

STEP 4 – WIRE HARNESS FOR THE COMPRESSOR AND VALVE BLOCK

Mount the two relays within two feet of the compressor and valve block using the 10-32 x 3/4" machine screws and 10-32 nylock nuts. Insert the red wire from the wire harness with the male spade terminal into the female spade terminal on the red wire from the compressor. Insert the black wire from the wire harness with the male spade terminal into the female spade terminal on the exhaust valve. Install the yellow wire from the wire harness with a ring terminal onto the open terminal on the pressure sensor. Tighten the nut on the pressure sensor terminal figure tight. **DONOT OVERTIGHTEN THE TERMINAL NUT.** The remaining red wire on the wire harness with the fuse will be connected to a 12 Volt, 20 Amp positive power source. *See Figure "A"*.

STEP 5 – MOUNT THE DIGITAL GAUGE

The digital gauge panel must be mounted in a dry protected location with a flat mounting surface. Install the two foam tape strips onto the back of the gauge and then firmly place the digital gauge panel onto the mounting location.

STEP 6 – WIRE HARNESS FOR THE DIGITAL GAUGE PANEL

Route the wire harness from the compressor and manifold block to the gauge. Use the nylon ties provided to secure the wire harness to the vehicle. Route the wire harness to avoid direct heat from the exhaust system and away from any sharp edges. Take the connector that is taped to the poly loom and insert the three wires into the connector as shown in *Figure "C"* until a clicking noise is heard. The red wire goes into port #1, the black wire goes into port #2 and the yellow wire goes into port number #3. **NOTE: once the terminals are in the connector there is no way to get them back out.** Connect the wire harness electrical connector to the digital gauge electrical connector.

There are two sets of wires coming from the digital gauge panel, one set with red, black and yellow wires, and one set with a red and black wire. Connect the red wire from the digital gauge panel to an ignition source under the dashboard. Connect the black wire to a suitable ground source. *See Figure "A"*.

STEP 7 – ROUTE THE AIR LINE

Cut a section of air line tubing that will reach from the compressor to the valve block. Cut the air line tubing as squarely as possible and insert the tubing into the male fitting on the compressor and then into the male fitting on the end of the valve block. Cut a section of air line tubing that will reach from the valve block to one of the air springs. Cut the air line tubing as squarely as possible and insert the tubing into the male fitting on the valve block and then insert the other end into the air spring. Use the nylon ties provided to secure the air line tubing to the vehicle. Route the tubing to avoid direct heat from the exhaust system and away from any sharp edges. Repeat this last step on the other air spring and remaining fitting.

STEP 8 – CHECK THE SYSTEM

With the Digital Air Command kit and the air springs installed you are ready to test the system. Re-attach the negative battery cable. Turn on the vehicle's ignition. Push and hold the up button to inflate the air springs. The gauge will display how much air pressure is in the system. Inflate the air springs to 70 psi or the max air spring pressure, whichever is less, and check the fittings for air leaks with a solution of soap and water. If a leak is detected at a tubing connection, check to make sure that the tube is cut as squarely as possible and that it is pushed completely into the fitting. The tubing can easily be removed from the fitting by first releasing the pressure from the air spring, then by pushing the collar towards the body of the fitting and holding, then pulling the tube out.

SYSTEM OPERATION

The Digital Air Command kit allows the air springs to be inflated from the inside of the vehicle. Push the top button to inflate the air springs and push the bottom button to deflate the air springs. The Digital Air Command kit will stop deflating at 5 psi and the digital gauge panel will flash red when the pressure is within the low pressure range. To make the digital gauge stop flashing red simply inflate the air springs to 5 psi or more. The Digital Air Command kit will stop inflating at 120 psi and the digital gauge panel will flash red when the pressure is within a high pressure range. To make the digital gauge stop flashing red simply deflate the air springs to less than 120 psi.



www.riderite.com