

Instructions for PowerTrac Brake Control

Electronic Brake Control For 2 to 4 brake applications.

READ THIS FIRST:

Read and follow all instructions carefully before installing or operating the brake control. Keep these instructions with the brake control for future reference.

Components of the Brake Control

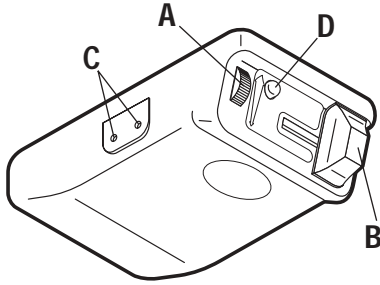

- A. Power Knob
- B. Manual Slide Knob
- C. Bracket Mounting Holes
- D. Bi-Colored Light

Important Facts to Remember

1. Do not mount or activate RF generating items (cell phones, two way radios) near (less than 12") the brake control.
2. Reversing the connection to a breakaway battery on the trailer will destroy the brake control.
3. Disconnect trailer plug from the tow vehicle prior to testing a breakaway switch, or you may destroy the brake control.
4. The light is:

- GREEN when trailer is connected
 - RED when brake pedal or manual is activated and trailer is connected.
 - *Flashing* RED or OFF when trailer is not connected.
5. The GREEN light draws 10 milliamperes of current from tow vehicle. It would take over 5,000 hours to drain the tow vehicles battery.
 6. For Technical Assistance and Warranty Information call toll-free: 1-888-785-5832 or www.tekonsha.com

Installation Guide

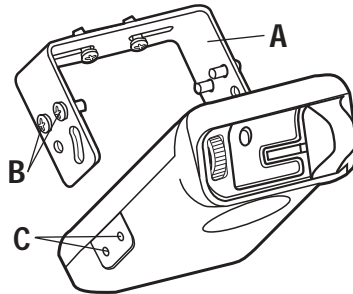

- A. Mounting Bracket
- B. #6 x 3/8" Screws
- C. Mounting Holes

NOTE: Drilling or use of longer screws may damage unit.

1. Securely mount *bracket* to a solid surface.
2. Insert supplied #6 x 3/8" screws on each side into the mounting holes.
3. Adjust control to desired position and tighten *screws* until snug.

Adjusting the Power to the Trailer Brakes

Once the control has been installed, it is

necessary to set the power needed to stop the trailer during a braking event.

1. Connect trailer to tow vehicle.
2. Locate the *manual slide knob* and *power knob* on the control.
3. Turn *power knob* to minimum. Turn *power knob* in the + direction about a 1/4 of a turn.
4. Drive tow vehicle and trailer on a dry level paved surface at 25 mph and apply *manual slide knob*.
 - ✓ If trailer brakes lock up:
 - Turn power down using *power knob*.
 - ✓ If braking was not sufficient:
 - Turn power up using *power knob*.
5. Repeat Step (4) until power has been set to a point just below wheel lock up or at a sufficient force as to achieve maximum braking power.

NOTE:

1. Always warm the trailer's brakes before setting the power. Warm trailer brakes tend to be more responsive than cold brakes. To warm trailer brakes, drive a short distance (1/4 mile) at 45 MPH with manual slide engaged approximately halfway.
2. The power should never be at a level high enough to cause trailer brakes to lock up. Skidding trailer wheels can cause loss of directional stability of trailer and tow vehicle. The power may need to be adjusted for different load weights and road conditions.
3. The driver may find it necessary to readjust the power to a lower setting for extended periods of in town stop and go driving. It is always good practice to readjust the power when returning to highway driving

PowerTrac Troubleshooting Chart

Situation	Probable Cause
No trailer brakes with manual knob activated. Light is GREEN.	- POWER set to minimum, adjust to a higher setting.
No trailer brakes with foot pedal depressed. Light is GREEN.	- POWER set to minimum, adjust to a higher setting. - RED (stoplight) wire connected incorrectly. - Bad connection on RED wire. - Blown stoplight fuse.
Trailer braking is weak. Light is GREEN / RED.	- POWER set too low, adjust to a higher setting. - Brake control grounded to interior of vehicle.
Trailer braking is weak or inconsistent Light is OFF, Flashing RED or DIM.	- Trailer is not connected to vehicle. - Open circuit on brake line. - Ground connection is poor. - No POWER to unit through BLACK wire.
Trailer braking is too strong. Light is GREEN / RED.	- POWER set too high, adjust to a lower setting.
Trailer brakes locked when connected to vehicle. Light is RED.	- RED (stoplight) wire connected incorrectly. - Breakaway system employed. - BLACK & WHITE wires reversed, control destroyed.
Light is GREEN all the time	- Short from brake line to ground. - BLACK & WHITE wires reversed, control destroyed.

BRAKE CONTROL WIRING INSTRUCTIONS

Wiring Instructions for Electronic Brake Controls

READ THIS FIRST:

Read and follow all instructions carefully before wiring brake control. Keep these instructions with the brake control for future reference.

Generic Wiring Diagram

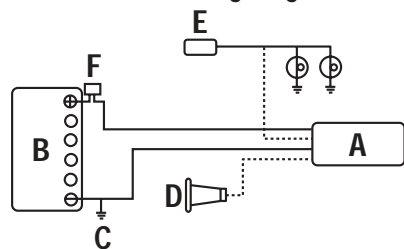

- A. Brake Control
- B. 12 Volt Battery
- C. Chassis Ground
- D. Trailer Connector
- E. Stoplight Switch
- F. Automatic Reset Circuit Breaker
- G. Turn / Brake Lights

Important Facts to Remember

1. The brake control must be installed with a 12 volt negative ground system. (To install with a positive ground system use Tekonsha Towing Systems P/N 3191)
2. Reversing BLACK and WHITE wires or improper wiring will damage or destroy brake control.
3. Be sure to solidly connect all four wires or brake control will not function properly.
4. Soldering is recommended or crimp-on butt connectors are a suitable substitution.
5. Route all wires as far from the radio antenna as possible to reduce AM interference.
6. Use of proper gauge wire when installing the brake control is CRITICAL, smaller gauge wire may result in less than efficient braking.
Minimum wire gauges are as follows:
 - 1-2 axle applications – 14 GA.
 - 3-4 axle applications – 12 GA.
7. Collection of water inside the trailer connector mounted on the tow vehicle will reduce the life of the connector. To minimize corrosion build up inside the connector:
8. Connector terminals should be completely covered with dielectric compound (*Tekonsha Towing Systems P/N 7200*)
9. Mount trailer connector such that the brake line and ground terminals are not located near the 6 o'clock position.
10. Technical Assistance Call Toll-Free: 1-888-785-5832 or www.tekonsha.com

Generic Wiring Instructions

NOTE: Please review your vehicle's Specific Wiring Section before continuing

Wiring Legend

- + BLACK Wire (Positive Battery)
- WHITE Wire (Negative Battery)
- ⊗ RED Wire (cold side of stoplight switch)
- BLUE Wire (brake output to trailer)

1. Using the appropriate hardware, connect the WHITE (-) wire to the NEGATIVE (-) terminal of the battery.

NOTE: Grounding to any other location than the negative terminal of the battery may cause intermittent braking or lack of sufficient voltage to trailer brakes. DO NOT ground the WHITE wire to the dash or other interior metal surfaces.

2. Connect BLACK (+) wire through an automatic reset circuit breaker (20 amp for 1-2 axles, 30 amp for 3-4 axles) to the POSITIVE (+) terminal of the battery. The BLACK wire is the power supply line to the brake control.
3. The RED (stoplight) wire must be connected to the cold side of the brake pedal stoplight switch. Splice down line from the switch, DO NOT disturb the position of the switch.
4. The BLUE (brake output) wire must be connected to the trailer connector's brake wire.

Specific Wiring Instructions for

NOTE:

1. For all Dodge tow vehicles equipped with the Factory Tow Package Brake Connector, the 15 amp fused power line will not be sufficient for 3 and 4 axle applications. For 3 and 4 axle applications, a separate power wire directly connected to the POSITIVE (+) terminal of the battery with a 30 amp automatic reset circuit breaker inline is required to be connected to the BLACK (+) wire of the brake control.

Daimler Chrysler Tow Vehicles

1988-1993 D and W Series:

The brake control's RED (stoplight) wire splices into the WHITE wire on the cold side of stoplight switch.

1994-1995 D and W Series and

1995-1996 Ram Van:

The brake control's RED (stoplight) wire splices into the WHITE WITH TAN TRACER wire on the cold side of the stoplight switch.

1996-1999 Dodge Ram / Dakota and

1999 Durango:

The factory Tow Package has a 4 pin connector located on the steering column under the dash. Follow factory supplied wiring instructions.

1988-1990 Jeep:

The brake control's RED (stoplight) wire splices into the LIGHT BLUE WITH BLACK TRACER wire on the cold side of the stoplight switch.

1991-1993 Jeep:

The brake control's RED (stoplight) wire splices into the WHITE WITH TAN TRACER wire on the cold side of the stoplight switch.

1994 and Newer Jeep:

Consult Jeep Dealer.

Specific Wiring Instructions for

NOTE:

1. Prior to 1992, the Ford Trailer Tow Package DOES NOT include the stoplight wire which the brake control's RED (stoplight) wire splices into.
2. For all Ford tow vehicles equipped with the Factory Tow Package Brake Connector, the 20 amp fused power line will not be sufficient for 3 and 4 axle applications. For 3 and 4 axle applications, a separate power wire directly connected to the POSITIVE (+) terminal of the battery with a 30 amp automatic reset circuit breaker inline is required to be connected to the BLACK (+) wire of the brake control.

FORD Tow Vehicles

Explorer, Ranger and Aerostars:

The brake control's RED (stoplight) wire splices into the cold side of the stoplight switch

1989 – 1991 E and F Series:

The brake control's RED (stoplight) wire must splice into the stoplight line via the turn signal harness. The turn signal harness is a crescent shaped connector attached to the steering column. The connector has two rows with four positions on the inner row and seven positions on outer row. The wire, which needs to be spliced into, is LIGHT GREEN in color and is located at the second position of the outer row of seven.

1992-1993 E and F Series:

The brake control's RED (stoplight) wire splices into the Ford 4-pin connector's LIGHT GREEN wire for F Series or LIGHT GREEN WITH RED TRACE for E Series. The connector is located at the bottom of the instrument panel, directly below the radio, for F Series, and near the brake pedal support arm for E Series.

1994-1999 E and F Series &

1997-1999 Expeditions and Navigators

The brake control's RED (stoplight) wire splices into the Ford 6-pin connector's LIGHT GREEN wire. The connector is attached to the computer module access located just right of the steering column.

1999 F250-F350:

The 6 pin connector is located behind the fuse panel just under the steering column (C).

1. Remove fuse panel (D), just to the right of the opening is a vertical panel and a 6-pin connector (A).

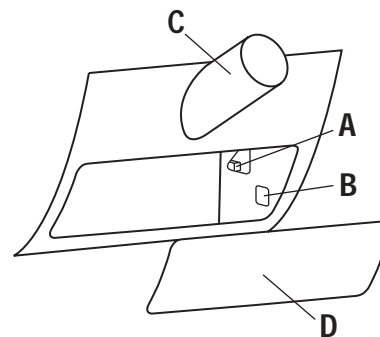

Specific Wiring Instructions for GM Tow Vehicles

1988-1993 S, T, C, K and G Series

1994 S, T and Suburban Series

The brake control's RED (stoplight) wire splices into the WHITE wire on the cold side of the stoplight switch.

1994 C, K and G Series

The brake control's RED (stoplight) wire splices into the YELLOW wire on the cold side of the stoplight switch.

1995-1996 All GM Tow Vehicles

The brake control's RED (stoplight) wire splices into a specific WHITE wire on a 10-pin connector. This connector is located to the left of the steering column. It is coming from the main loom of wires going into the instrument panel. The connector is WHITE and is wrapped with gray foam tape, it will have two WHITE wires exiting the connector. The correct wire is the WHITE wire located in corner (F position) of the connector. Splicing into this specific wire will eliminate any problems with electrical circuits associated with ABS or the cruise control.

1997 GM Full Size Trucks

1. Locate the convenience center at the firewall just under the emergency brake pedal.
2. Remove 6-8" of tape covering main loom of 40+ wires.
3. You will find:
 - 5 WHITE Wires
 - 4 light gauge wires (16 GA.)

BRAKE CONTROL WIRING INSTRUCTIONS

Wiring Instructions for Electronic Brake Controls (continued)

2. There is an access hole (B) the lower right corner of this panel. Feed the connector, supplied with your Tow Package, through this hole and up to the fixed connector mounted on panel.
3. Connect the brake control's wires to the connector's pigtail following Tow Package Instructions.

- 1 heavy gauge wire (14 GA.)
 - Multiple wires wrapped with YELLOW tape. (DO NOT DISTURB, AIR BAG SENSOR WIRES)
4. Probe the 4 light gauge wires with a test light.
 5. The wire that is cold until brake pedal is depressed and does not flash with hazard flashers activated is the correct wire. Splice that wire into the brake control's RED (stoplight) wire.
 6. Rewrap remaining wires.

Old Style Convenience Center

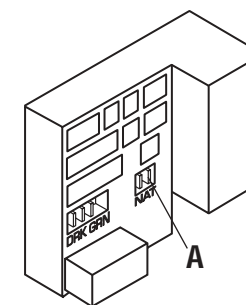

1998-1999 GM Truck, Suburban, and Tahoe

1. Locate the convenience center at the firewall just under the emergency brake pedal.
2. At the bottom of the convenience center locate the bottom row of cavities marked:
 - DRK GRN (Rectangular Shaped)
 - NAT (Square Shaped)
3. Inside the small square cavity (NAT) are two male spade terminals. The spade terminal on the right is the Stoplight Feed (A).
4. Connect an INSULATED 1/8" female spade terminal to the brake control's RED (stoplight) wire.
5. Connect the female spade terminal to the male terminal specified in STEP 3.

1999 Silverado and Sierra Trucks

GM provided a 6-pin connector for an electronic brake control for the following trim levels:

- LS in late 1999 model year production.
- LT for all 1999 model year production.

 To see if your truck has this new 6-pin connector, see image below (*New Style Convenience Center*).

New Style Convenience Center

- Find convenience center at the lower left side of the firewall inside the cab.
- Remove the cover by unscrewing the large black nut in the center of the cover.

- Pull off cover, look at the large cavities at the top.
- The second cavity (A) from the left will be the 6-pin connector for electronic trailer brakes.

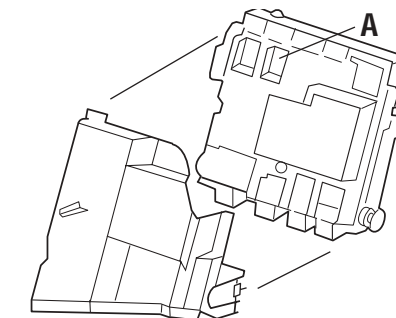

If your truck:

- DOES NOT have this style of convenience center, see instructions for *1998-1999 GM Truck, Suburban, and Tahoe*.
- DOES have this style of convenience center, see instructions below for *1999 New Style Convenience Center*.

1999 New Style Convenience Center

• WITHOUT Trailer Tow Package

This connector will be available on all models without trailer tow option. However, the only wires that are useable at the connector end will be the stoplight (RED) and ground (WHITE). The 12 volt power line (BLACK) and electric trailer brake (BLUE) will terminate just under the vacuum assist outside the firewall. Therefore, the BLACK and BLUE wires will have to be run to the battery (BLACK) and trailer connector (BLUE). The mating 6-pin connector is available from GM (P/N 12171982) or Tekonsha Towing Systems (P/N 3025) that will interface with the 6-pin connector in the convenience center. Once again this connector will not be fully functional until power (BLACK) is run to the positive side of the battery through an automatic reset circuit breaker, and the electric trailer brake (BLUE) is connected to the trailer connector at the rear of the vehicle. These wires can be found under the vacuum assist in the engine compartment.

• WITH Trailer Tow Package

All vehicles with trailer tow option will have a mating 6-pin connector located in the glove box. Connect the brake control to the mating connector following GM instructions included with the connector.