

Kit No. 59102 (Fits 2" & 4" Drops)

NOTE: If the bottom of the frame to the leaf spring is between 7.0 & 8.5 use kit #59104.

Please read these instructions completely before proceeding with installation.

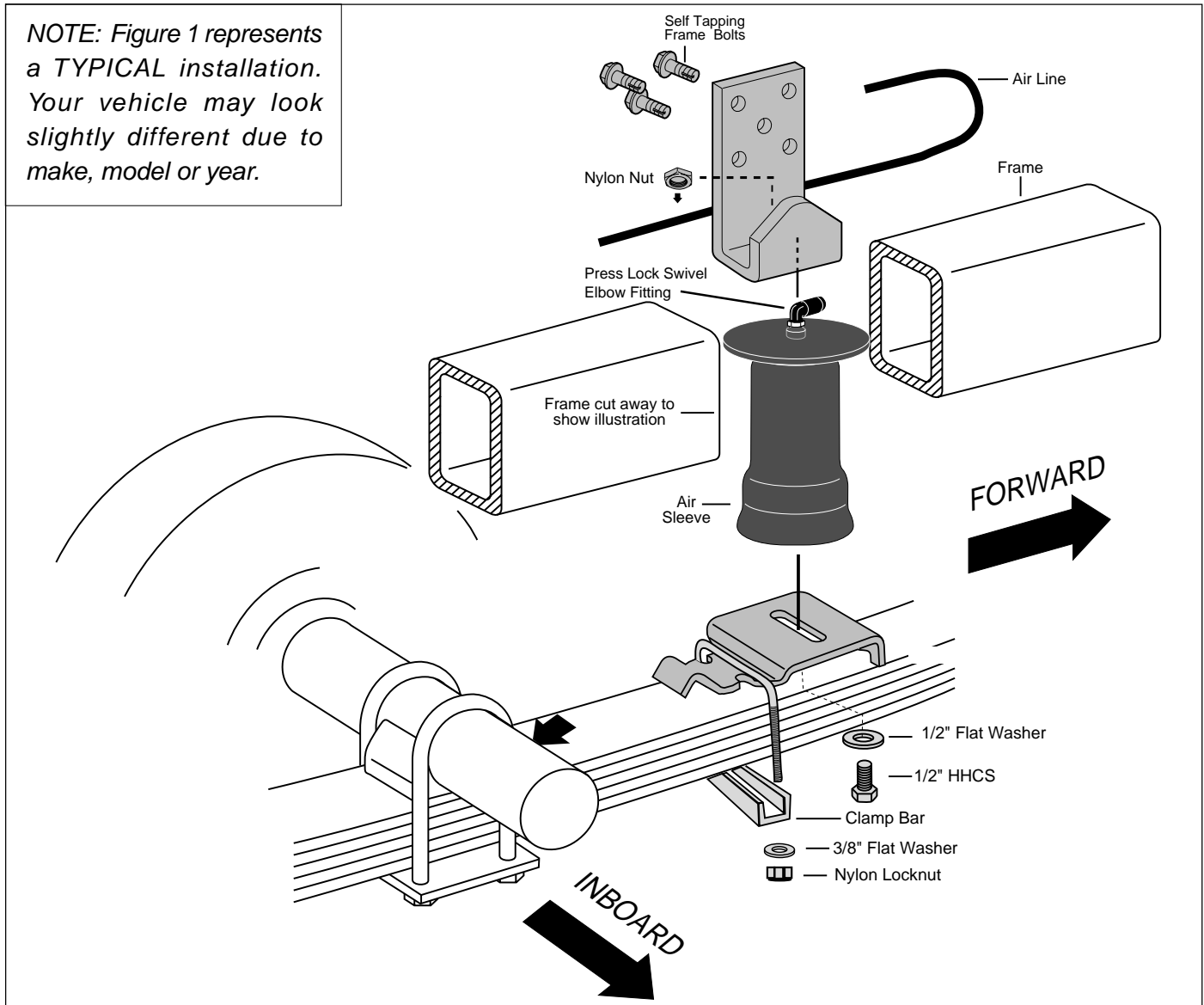

Figure 1

WARNING: Do not inflate assembly when it is unrestricted. Assembly must be restricted by suspension or other adequate structure. Do not inflate beyond 100 p.s.i. Improper use or over-inflation may cause assembly to burst causing property damage or severe personal injury.

IMPORTANT: Ride height (no load)- This is the distance between the bottom of the bumper and a flat road surface with the vehicle in its "lowered" condition without anything in the bed of the truck. Take a measurement before installation and note it. All AIR LIFT kits are designed to be installed and operated at Ride Height.

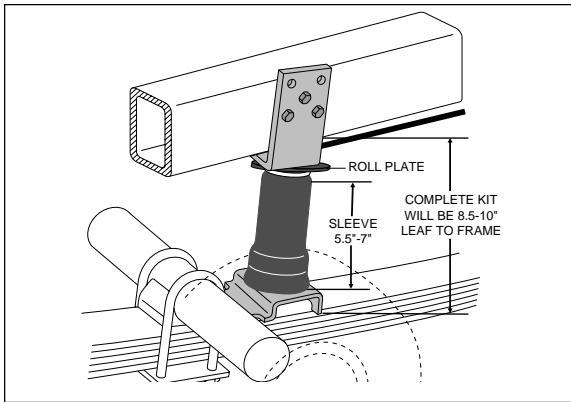

Figure 2

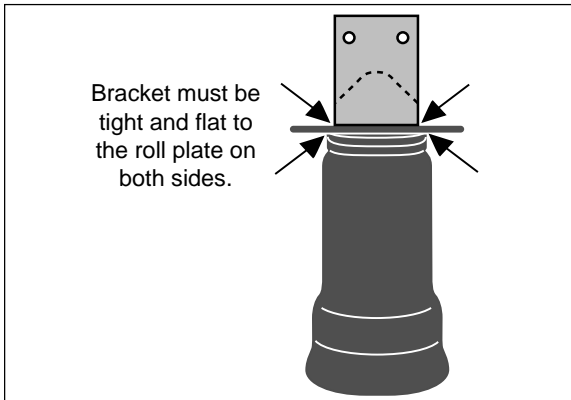

Figure 3

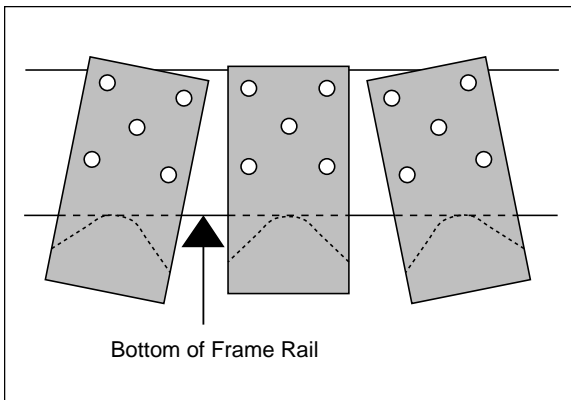

Figure 4

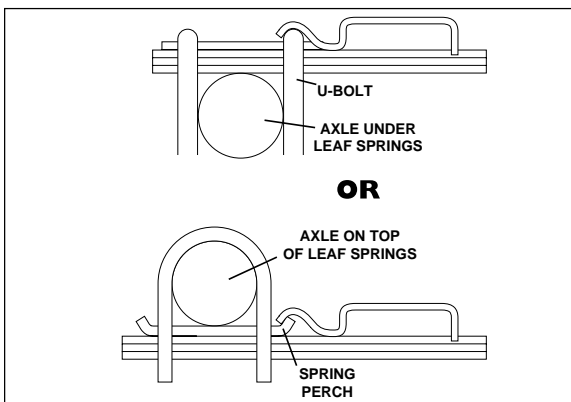

Figure 5

Please read these instructions completely before attempting the installation.

This kit is designed to fit most down sized pick ups and sport utility vehicles that have been lowered where the leaf springs are located directly below the frame rail. Kit #59102 is an under the frame kit which means that the kit mounts from the bottom of the frame rail to the top of the leaf spring. Due to the wide variety of lowering kits on the market, Air Lift cannot guarantee that this kit will fit every vehicle. You may need to modify the upper bracket, or even weld it, depending on the type of kit the vehicle was lowered with. This will not void the warranty. The sleeve must be mounted between 7" and 9" at ride height. To achieve this dimension, you will need 8.5"–10" of space between the top of the leaf spring and the bottom of the frame rail in front or behind the axle (Figure 2). If you find the space between the spring and frame rail is 7.0" to 8.5", you will need to exchange this kit for kit #59104 or call Air Lift Customer Service at 1-800-248-0892. If measurement is below 7.0" we do not fit your application.

NOTE: This is a universal kit for custom applications. In no way should the sleeve or any of the kit's components be the suspension limiter in compression or extension. This air spring can compress to 3.0" and extend to 11". Regardless of load, the air pressure should be adjusted so that the ride height is maintained at all times. The shock absorber is usually the limiter on extension. If this is not the case, you should consider the use of limiting straps. For technical assistance call Air Lift Technical Service at 1-800-248-0892.

1. After recording the ride height, jack up rear of vehicle or raise on hoist and remove rear wheels.
2. Install swivel air fitting to the top of the sleeve and tighten finger tight plus 1 1/2 turns. Use a 7/16" open end wrench being careful to tighten on the metal hex nut only. *Do not overtighten.* This fitting is pre-coated with thread sealant. Now set the upper bracket onto the thread post of the air spring. Thread nylon nut onto the thread post with the flat side up. The bracket must be tight and flat to the roll plate on both sides. Hand tight is sufficient (Figure 3). Be sure the swivel air fitting faces the front of the vehicle. *Loosely* attach the lower bracket to the bottom of the air spring (Figure 1).
3. Set the assembly on the leaf spring in front or behind depending on what would interfere with function of kit. It is permissible to stagger kit also, in case shocks or brake lines that interfere with kit. The lower bracket has a "finger" that is designed to "hook" around something like a U-bolt, spring retainer, or spring perch (Figure 5). This keeps the lower bracket from "walking" up the spring which would cause damage to the air springs. If the vehicle does not have something for the "finger" to "hook" to, install the L-bracket supplied in this kit for that function. Refer to SB-171 for instructions on how to install the L-bracket. With lower bracket in place install U-bolt, clamp bar, flat washer and locknut. Torque to 16 ft-lbs (Figure 1).

- The upper bracket must be parallel and perpendicular to the lower bracket (Figure 6). The upper bracket is designed so that it can be "titled" for the proper angle (Figure 4). The bottom of the upper bracket must fit tight to the bottom of the frame rail (Figure 7). It is necessary to use at least three of the five predrilled mounting holes in the upper bracket. Any combination of three is permissible. **CAUTION:** Do not drill any holes into the frame until all hydraulic lines, gas lines, and electrical wires have been moved aside on both sides of the frame rail. Using the bracket as a template, center punch and drill three $\frac{5}{16}$ " holes. **NOTE:** The holes must be no larger than $\frac{5}{16}$ ". Attach the upper bracket using the self-tapping frame bolts and tighten securely (Figure 1). Do not over tighten.

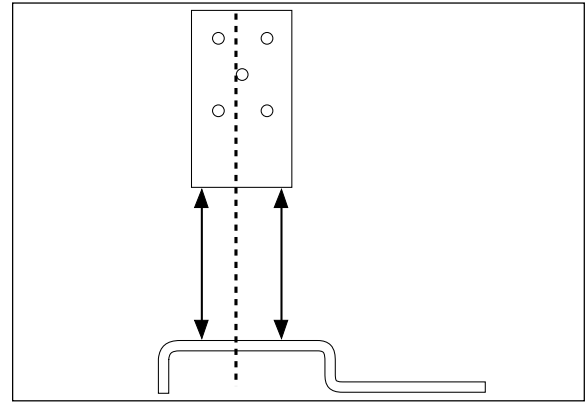
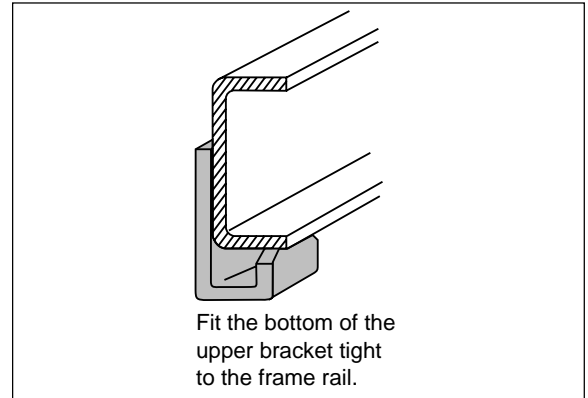

Figure 6

- Select a location for the inflation valves in the rear bumper area or rocker panel flange insuring that each valve will be protected and accessible with an air hose (Figure 8).
- Use a standard tube cutter, a razor blade, or very sharp knife to cut the air line in two equal lengths. A clean square cut will ensure against leaks. Drill a $\frac{5}{16}$ " hole for inflation valve and mount as illustrated. The rubber washer on the outside is for weather seal (Figure 9).



Fit the bottom of the upper bracket tight to the frame rail.

Figure 7

- Route air line along frame from desire location valve location to the air fitting (Figure 8). Attach air line to chassis with the provided plastic straps.

IMPORTANT: To prevent air line from melting, keep it at least 12" from the exhaust system.

- Cut off excess air line squarely and install the air line into the fitting. This is a self locking fitting. Push and slightly turn the cut end of the air line into the fitting as far as it will go. A definite "click" can be heard/felt when the air line is seated. The air line will go into the fitting about $\frac{9}{16}$ ".
- Repeat process for right side.

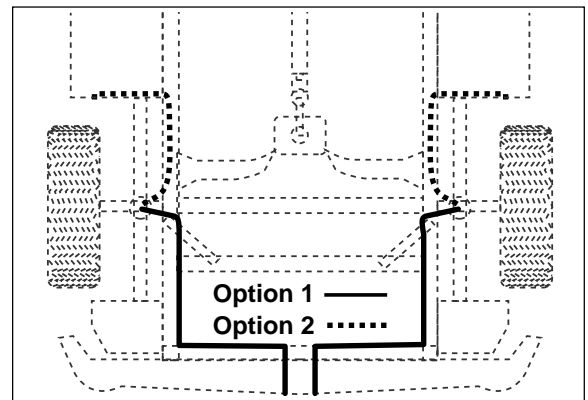

Figure 8

- IMPORTANT:** With the bottom still loose, inflate the air spring to approximately 10 p.s.i. By using the slotted adjustments, center the air spring so that it is in line with the upper and lower bracket and that there is a symmetrical cushion of air around the lower pedestal of the air spring to prevent side load wear (Figure 10). Air spring diameter grows to 4.6" at maximum inflation, check to be sure there is sufficient clearance around the air spring when it is inflated. Tighten the lower air spring mounting bolt to 10 ft-lbs.
- Inflate to 30 p.s.i. Check all fittings and valve core with a soapy water solution for leaks. Recheck air pressure after 24 hours. A 2–4 p.s.i. loss after initial installation is normal. If pressure has dropped more than 5 lbs, then retest for leaks with a solution of $\frac{1}{5}$ dish soap to $\frac{4}{5}$ water. Please read and follow the Maintenance and Operating Tips.

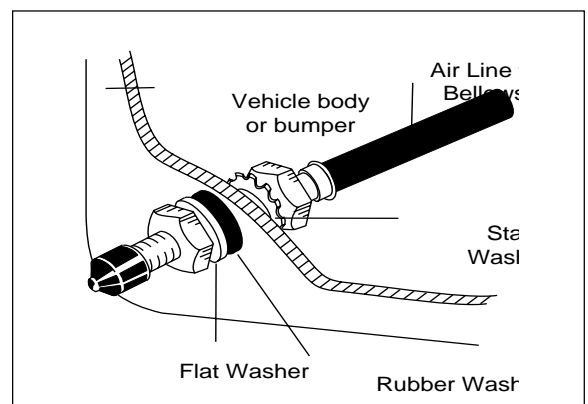

Figure 9

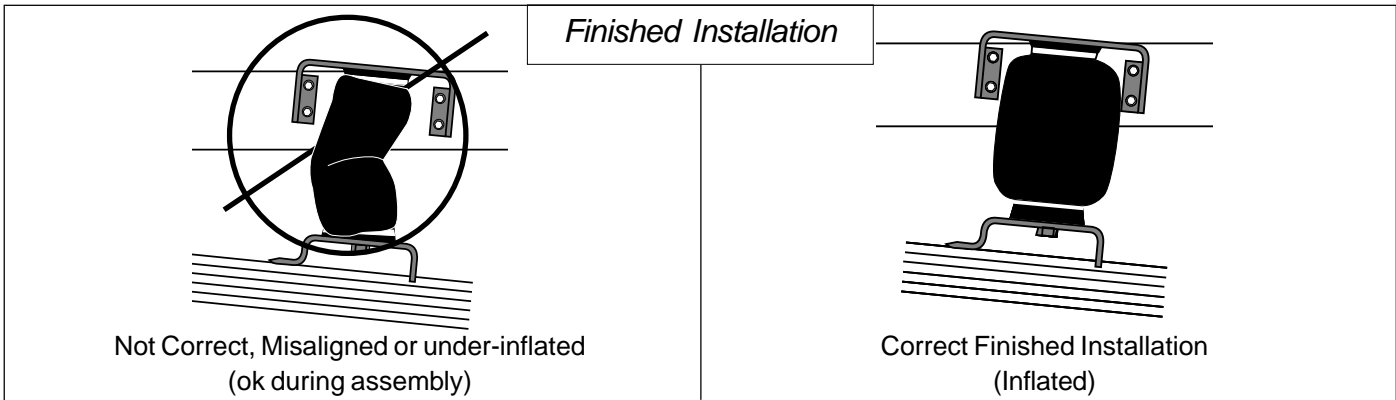

Figure 10

MAINTENANCE AND OPERATION:

<i>Minimum Pressure</i>	<i>Maximum Pressure</i>
<i>10 p.s.i</i>	<i>100 p.s.i.</i>
<p><i>Failure to maintain correct minimum pressure (or pressure proportional to load), bottoming out, overextension, or rubbing against another component will void the warranty.</i></p>	

By following these steps, vehicle owners should obtain the longest life and best results from their air springs.

1. Check the air pressure in the air springs weekly.
2. Always maintain Ride Height. Never inflate beyond 100 p.s.i.
3. If you develop an air leak in the system, use a soapy water solution to check all air line connections and the inflation valve core before deflating and removing the air spring.
4. Inflate your air springs to 60 p.s.i. before adding the payload. After vehicle is loaded, adjust your air pressure to level the vehicle and for ride comfort.
5. When you are carrying a payload it will be helpful to increase the tire inflation pressure in proportion to any overload condition. We recommend a 2 p.s.i. increase above normal (not to exceed tire manufacturer maximum) for each 100 lbs. total overload on the axle.
6. Always adjust the air pressure to maintain Ride Height. Increase or decrease pressure from the system as necessary to attain Ride Height for optimal ride and handling. Remember that loads carried behind the axle (including tongue loads) require more leveling force (pressure) than those carried directly over the axle.
7. **IMPORTANT:** For your safety and to prevent possible damage to your vehicle, *do not exceed Maximum Gross Vehicle Weight Rating (GVWR), as indicated by the vehicle manufacturer.* Although your air springs are rated at a maximum inflation pressure of 100 p.s.i. The air pressure actually needed is dependant on your load and GVWR, which may be less than 100 p.s.i. Check your vehicle owners manual and do not exceed the maximum load listed for your vehicle.
8. Always add air to springs in small quantities, checking the pressure frequently. Air springs require less air volume than a tire and inflate quickly.
9. Should it become necessary to raise the vehicle by the frame or do any service work, make sure the system is at minimum pressure (10 p.s.i.) for safety and to reduce the tension on the suspension/brake components.

	<i>Thank you for purchasing Air Lift Products</i>	
	Mailing Address:	Street Address:
	AIR LIFT COMPANY	AIR LIFT COMPANY
	P.O. Box 80167	2710 Snow Rd.
Lansing, MI 48908-0167	Lansing, MI 48917	
Local Phone: (517) 322-2144		
Fax: (517) 322-0240		
<p>For Technical Assistance call 1-800-248-0892</p>		

“The Choice of the Professional Installer” Printed in the USA



Product Use Information

Frequently asked questions

Q. Will installing air springs increase the weight ratings of a vehicle?

No. Adding air springs will not change the weight ratings (GAWR, GCWR and/or GVWR) of a vehicle. Exceeding the GVWR is dangerous and voids the Air Lift warranty.

Q. Is it necessary to keep air in the air springs at all time and how much pressure will they need?

The minimum air pressure should be maintained at all times. The minimum air pressure keeps the air spring in shape, ensuring that it will move throughout its travel without rubbing or wearing on itself.

Q. Is it necessary to add a compressor system to the air springs?

No. Air pressure can be adjusted with any type of compressor as long as it can produce sufficient pressure to service the springs. Even a bicycle tire pump can be used, but it's a lot of work.

Q. How long should air springs last?

If the air springs are properly installed and maintained they can last indefinitely.

Q. Will raising the vehicle on a hoist for service work damage the air springs?

No. The vehicle can be lifted on a hoist for short-term service work such as tire rotation or oil changes. However, if the vehicle will be on the hoist for a prolonged period of time, support the axle with jack stands in order to take the tension off of the air springs.

Tuning the air pressure

Pressure determination comes down to three things — level vehicle, ride comfort, and stability.

1. Level vehicle

If the vehicle's headlights are shining into the trees or the vehicle is leaning to one side, then it is not level (fig. 1). Raise the air pressure to correct either of these problems and level the vehicle.

2. Ride comfort

If the vehicle has a rough and harsh ride it may be due to either too much pressure or not enough (fig. 2). Try different pressures to determine the best ride comfort.

3. Stability

Stability translates into safety and should be the priority, meaning the driver may need to sacrifice a perfectly level and comfortable ride. Stability issues include roll control, bounce, dive during braking and sponginess (fig. 3). Tuning out these problems usually requires an increase in pressure.

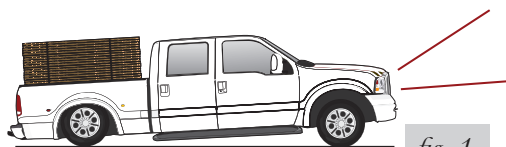

Bad headlight aim

fig. 1



Sway and body roll

fig. 2



Rough ride

fig. 3

Guidelines for adding air:

1. Start with the vehicle level or slightly above.
2. When in doubt, always add air.
3. For motorhomes, start with 50-100 PSI in the rear because it can be safely assumed that it is heavily loaded.
4. If the front of the vehicle dives while braking, increase the pressure in the front air bags, if equipped.
5. If it is ever suspected that the air bags have bottomed out, increase the pressure (fig. 4).
6. Adjust the pressure up and down to find the best ride.
7. If the vehicle rocks and rolls, adjust the air pressure to reduce movement.
8. It may be necessary to maintain different pressures on each side of the vehicle. Loads such as water, fuel, and appliances will cause the vehicle to be heavier on one side (fig. 5). As much as a 50 PSI difference is not uncommon.

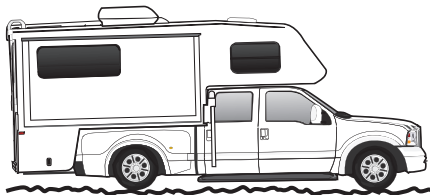

Bottoming out

fig. 4

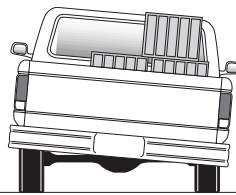

Unlevel

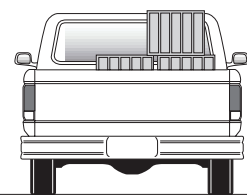

Level

fig. 5

Warranty and Returns Policy

Air Lift Company warrants its products, for the time periods listed below, to the original retail purchaser against manufacturing defects when used on catalog-listed applications on cars, vans, light trucks and motorhomes under normal operating conditions for as long as Air Lift manufactures the product. The warranty does not apply to products that have been improperly applied, improperly installed, used in racing or off-road applications, used for commercial purposes, or which have not been maintained in accordance with installation instructions furnished with all products. The consumer will be responsible for removing (labor charges) the defective product from the vehicle and returning it, transportation costs prepaid, to the dealer from which it was purchased or to Air Lift Company for verification.

Air Lift will repair or replace, at its option, defective products or components. A minimum \$10.00 shipping and handling charge will apply to all warranty claims. Before returning any defective product, you must call Air Lift at (800) 248-0892 in the U.S. and Canada (elsewhere, (517) 322-2144) for a Returned Materials Authorization (RMA) number. Returns to Air Lift can be sent to: Air Lift Company • 2727 Snow Road • Lansing, MI • 48917.

Product failures resulting from abnormal use or misuse are excluded from this warranty. The loss of use of the product, loss of time, inconvenience, commercial loss or consequential damages is not covered. The consumer is responsible for installation/reinstallation (labor charges) of the product. Air Lift Company reserves the right to change the design of any product without assuming any obligation to modify any product previously manufactured.

This warranty gives you specific legal rights and you may also have other rights that vary from state-to-state. Some states do not allow limitations on how long an implied warranty lasts or allow the exclusion or limitation of incidental or consequential damages. The above limitation or exclusion may not apply to you. There are no warranties, expressed or implied including any implied warranties of merchantability and fitness, which extend beyond this warranty period. There are no warranties that extend beyond the description on the face hereof. Seller disclaims the implied warranty of merchantability. (Dated proof of purchase required.)

Air Lift 1000	Lifetime Limited
RideControl	Lifetime Limited
SlamAir	Lifetime Limited
LoadLifter 5000*	Lifetime Limited
EasyStreet Systems	1 Year Limited

Load Controller (I)	2 Year Limited
Load Controller (II)	2 Year Limited
SmartAir	2 Year Limited
Wireless AIR	2 Year Limited
Other Accessories	2 Year Limited

**formerly SuperDuty*