

GMR15MR

Rear suspension package Ensemble pour suspension arriere Ensemble para suspension de delantero

INSTALLATION INSTRUCTION

- Raise vehicle allowing the axle to hang freely.
- Remove existing bump stop assembly.
- Assemble AEON rubber spring as shown in diagram. It is recommended to tight fastener #3 with Loctite®.
- Lower vehicle.

NOTE:

Ensure AEON rubber spring will not interfere to any parts of the vehicle.

Do not exceed vehicle manufacturer's recommended axle weight rating. Check for AEON® interference with vehicle components - Under load AEON® will "expand" in diameter.

INSTRUCTIONS DE MONTAGE

- Soulever le véhicule pour permettre à l'essieu de pendre librement.
- Enlevez l'assemblage de butée de bosse existant.
- Assemblez le ressort en caoutchouc AEON comme indiqué sur le schéma. Il est recommandé de serrer la fixation #3 avec du Loctite®.
- Abaisser le véhicule.

REMARQUES:

S'assurer que le ressort en caoutchouc AEON n'interférera pas à toutes les parties du véhicule.

Ne pas dépasser le poids nominal sur l'essieu recommandé par le fabricant du véhicule. Vérifier que le ressort AEON® n'a pas d'incidence sur d'autres pièces du véhicule - Le ressort AEON® augmentera son diamètre avec la charge.

INSTRUCCIONES DE INSTALACION

- Levante el vehículo permitiendo que el eje cuelgue libremente.
- Retire el conjunto de tope existente.
- Ensamble el resorte de goma AEON como se muestra en el diagrama. Se recomienda apretar el sujetador # 3 con Loctite®.
- Bajar vehículo.

NOTAS:

Asegúrese de que el resorte de goma AEON no interfiera a cualquier parte del vehículo.

No exceda la carga nominal en el eje recomendada por el fabricante del vehículo. Compruebe que no haya interferencia entre el resorte AEON® y los otros componentes del vehículo. Bajo carga, el resorte AEON® se amplía en diámetro.

Ref. =Reference =No. de référence =Núm. de referencia
Part =Part #. =No. de pièce =Núm. de pieza
Qty. =Quantity =Quantité =Cantidad

Ref	Part	Qty
1	A16137-003	2
2	A00545-65Q30	2
3	F11540-750	2

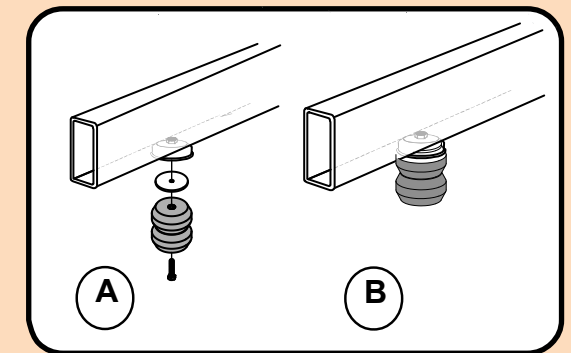
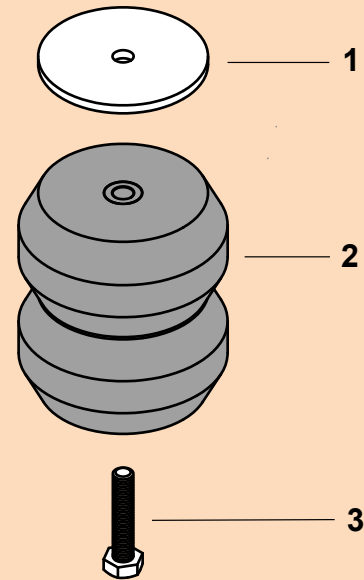

GMR15MR



GMR15MR

TIMBREN INDUSTRIES INC.

www.timbren.com

PART NUMBER	DESCRIPTION	QTY	LOCATION
F11540-750	HCS M10 x 5 x 1.50 F/T Gr. 8.8 Z	2	I2D
A00545-65Q30	HOLLOW RUBBER SPRING	2	C9B
A16137-003	DISC 3-1/4 OD x 13/32 ID x 3/16 Thick PAINTED	2	D20B
B90200-CR	SMALL REAR BOX - 9.5 x 7 x 5.5	1	A--E
B10000	8" X 12" BUBBLE FOR KITS	1	
B00029-010	BARCODE LABEL FOR KIT	1	

ASSEMBLY NOTES:

Issued: 6/21/2019

Clearance Instructions:

Rear SES Kits for Pick-Ups and Vans should have a 1/2" to 1-1/2" gap between the rubber spring and contact point when empty.

A partial load, or vehicle accessories will reduce or eliminate the gap.

Front SES kits are usually in full contact.

Medium and Heavy-Duty Trucks, Trailers and Motorhomes will be in constant contact, and have no gap.

Lifetime Warranty:

Timbren SES Kits are warranted against defects in material and workmanship, under normal use and service, for the life of the vehicle on which the kit was originally installed. The warranty is not transferable and proof of purchase is required. The warranty is limited to the replacement of the failed part.

TIMBREN will not be responsible for any labour or freight charges involved in the replacement of any product. TIMBREN shall be entitled to make its own inspection to determine the validity of the claim. TIMBREN shall not be liable nor warranty the product in the event of alteration, misuse, overload, negligence or damage caused by others.

If ride or performance of our product is unsatisfactory in any way, please call: 1-800-263-3113 or email sales@timbren.com